



Pressure Switch Model: PS40-1 & PS40-2

General Description

The Potter PS40 Series Supervisory Pressure Actuated Switches are designed primarily to detect an increase and/or decrease from normal system pressure in automatic fire sprinkler systems. Typical applications are: Dry pipe systems, pre-action air/nitrogen supervision, pressure tanks, air supplies, and water supplies. The PS40 switch is factory set for 2.8 bar (40 psi) normal system pressure. The switch marked with the word LOW is set to operate at a pressure decrease of 0.7 bar (10 psi) at 2.1 bar (30 psi). The switch marked with the word HIGH is set to operate at a pressure increase of 0.7 bar (10 psi) at 3.5 bar (50 psi). See section heading Adjustments and Testing if other than factory set point is required.

Installation

1. Connect the PS40 to the system side of any shutoff or check valve.
2. Apply Teflon tape to the threaded male connection on the device. (Do not use pipe dope)
3. Device should be mounted in the upright position. (Threaded connection down)
4. Tighten the device using a wrench on the flats on the device.

Wiring Instructions

1. Remove the tamper resistant screw with the special key provided.
2. Carefully place a screwdriver on the edge of the knockout and sharply apply a force sufficient to dislodge the knockout plug. See Fig. 9
3. Run wires through an approved conduit connector and affix the connector to the device. A NEMA-4 rated conduit fitting is required for outdoor use.
4. Connect the wires to the appropriate terminal connections for the service intended. See Figures 2, 4, 5, 6 and 8

Adjustment And Testing

The operation of the supervisory pressure switch should be tested upon completion of installation and periodically thereafter in accordance with the applicable NFPA codes and standards and/or the authority having jurisdiction (manufacturer recommends quarterly or more frequently).

The operation point of the PS40 Pressure Switch can be adjusted to any point between 0.7 - 4.11 BAR (10 and 60 PSI) by turning the adjustment knob(s) clockwise to raise the actuation point and counter clockwise to lower the actuation point. In the case of the PS40-2, both switches operate independent of each other. Each switch may be independently adjusted to actuate at any point across the switch adjustment range. Initial adjustment can be made with a visual reference from the top of the adjustment knob across to the printed scale on the switch bracket. Final adjustments should be verified with a pressure gauge.



Technical Details

Working Pressure	UL & FM - 20.7 bar (300 psi) LPCB - 17.2 bar (250psi) VdS - 16 bar (230 psi)
Adjustment Range	0.7 - 4.1 bar (10 - 60 psi)
Factory Adjustment	PS40-1 operates on decrease at 2.1 bar (30 psi) PS40-2 operates in increase at 3.5 bar (50 psi) and on decrease at 2.1 bar (30 psi)
Differential	Typical 0.07 at 0.7 bar (1 lb. at 10 psi) 0.28 at 4.1 BAR (4 lbs. at 60 PSI)
Dimensions	9,6cm x 8,1cm x 10,7cm (W x D x H) 3,78" x 3,20" x 4,22" (W x D x H)
Connection	Nylon 1/2" NPT Male
Contact Ratings	SPDT (Form C) 10.1 Amps at 125/250VAC, 2.0 Amps at 30VDC One SPDT in PS40-1, Two SPDT in PS40-2
Conduit Entrances	Two knockouts provided for 1/2" conduit.
Enclosure	Cover - Die-cast with textured red powder coat finish, single cover screw and rain lip. Base - Die-cast
Environmental Specification	• NEMA 4/IP66 Rated Enclosure - indoor or outdoor when used with NEMA 4 conduit fittings. • Temperature range: -40°C to 60°C (-40° - 140°F)
Service Use	Automatic Sprinkler - NFPA-13 One or two family dwelling - NFPA-13D Residential occupancy up to four stories - NFPA-13R National Fire Alarm Code - NFPA-72

Manufactured by Potter who hold FM Approval, UL Listing, LPCB, VdS and CE Certificates

DS: 2.33

Issue A

05/05/2021

© 2021 Potter

Rapidrop Global Ltd

T: +44 (0) 1733 847 510 F: +44 (0) 1733 553 958

e: rapidrop@rapidrop.com

Pressure Switch

Model: PS40-1 & PS40-2

Dimensions

Fig. 1

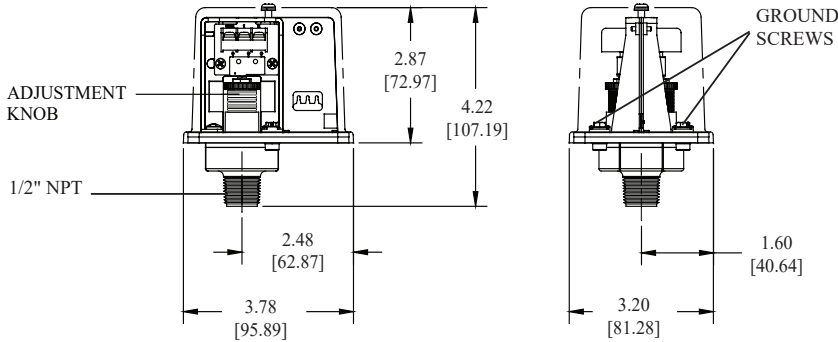

NOTE: To prevent leakage, apply Teflon tape sealant to male threads only.

⚠ WARNING

Use of pipe joint cement may result in obstruction of the aperture and loss of signal.

Switch Clamping Plate Terminal

Fig. 2

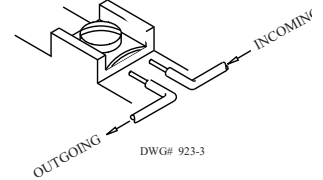

⚠ WARNING

An uninsulated section of a single conductor should not be looped around the terminal and serve as two separate connections. The wire must be severed, thereby providing supervision of the connection in the event that the wire becomes dislodged from under the terminal.

Typical Sprinkler Applications

Fig. 3

⚠ CAUTION

Closing of any shutoff valves between the alarm check valve and the PS10 will render the PS10 inoperative. To comply with IBC, IFC, and NFPA-13, any such valve shall be electrically supervised with a supervisory switch such as Potter Model RBVS

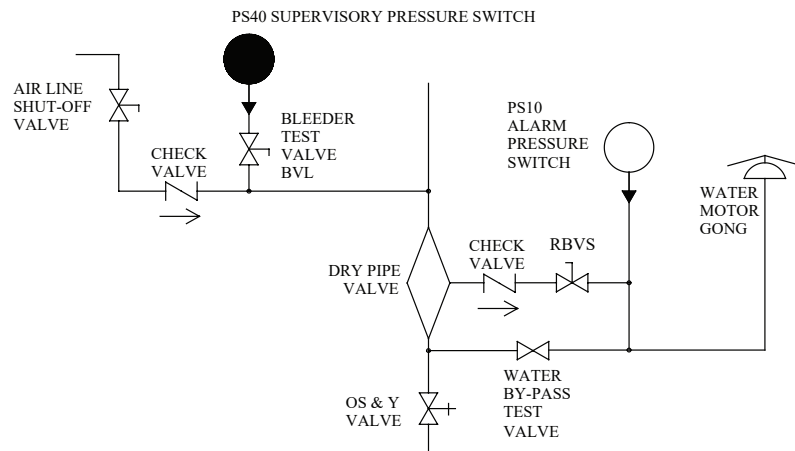

Typical Connections

Fig. 4

WITH NORMAL SYSTEM PRESSURE APPLIED LOW - TERMINAL 2 CLOSES ON PRESSURE DROP.

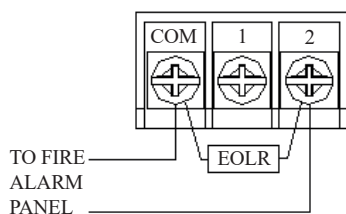

PS40-1

PS40-2

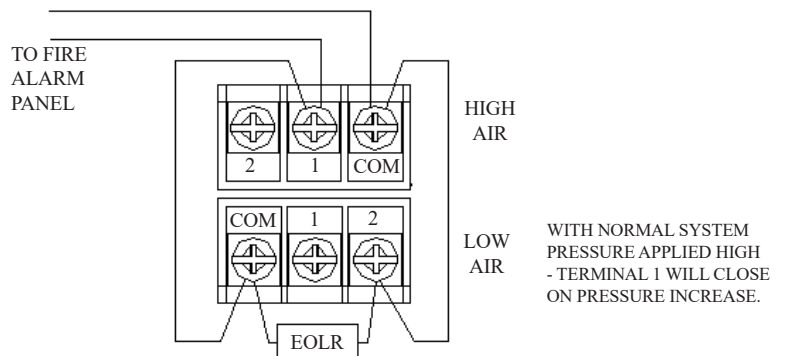

Manufactured by Potter who hold FM Approval, UL Listing, LPCB, VdS and CE Certificates



Pressure Switch Model: PS40-1 & PS40-2

Low Pressure Signal Connection

Fig. 5

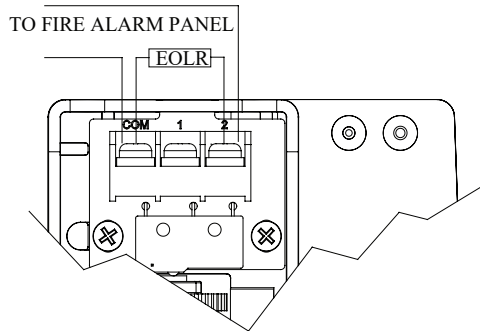

High Pressure Signal Connection

Fig. 6

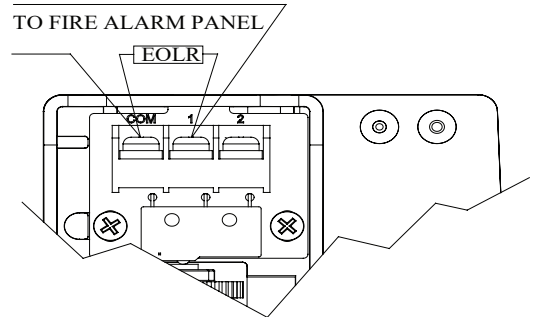

One Conduit Wiring

Break out thin section of divider to provide path for wires when wiring both switches from one conduit entrance.

Fig. 7

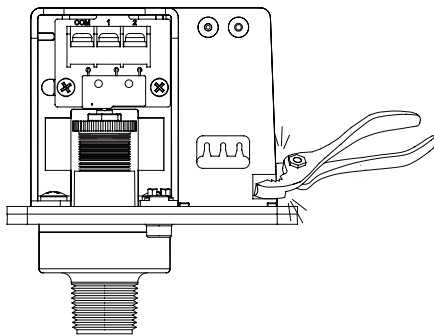

Switch Operation

(With normal system pressure)

Fig. 8

Terminal
C: Common
1: Closed when installed under normal system pressure.
2: Open when installed under normal system pressure. Closes on pressure drop. Use for low air signal.

LOW PRESSURE SWITCH

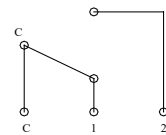

Terminal

1: Open when installed under normal system pressure. Closes on increase in pressure. Use for high air signal.
2: Closed under normal system pressure.

HIGH PRESSURE SWITCH

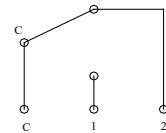

Warning

- Installation must be performed by qualified personnel and in accordance with all national and local codes and ordinances.
- Shock hazard. Disconnect power source before servicing. Serious injury or death could result.
- Read all instructions carefully and understand them before starting installation. Save instructions for future use. Failure to read and understand instructions could result in improper operation of device resulting in serious injury or death.
- Risk of explosion. Not for use in hazardous locations. Serious injury or death could result.

Caution

- Do not tighten by grasping the switch enclosure. Use wrenching flats on the bushing only. Failure to install properly could damage the switch and cause improper operation resulting in damage to equipment and property.
- To seal threads, apply Teflon tape to male threads only. Using joint compounds or cement can obstruct the pressure port inlet and result in improper device operation and damage to equipment.
- Do not over tighten the device, standard piping practices apply.
- Do not apply any lubricant to any component of the pressure switch.

Removing Knockouts

Fig. 9

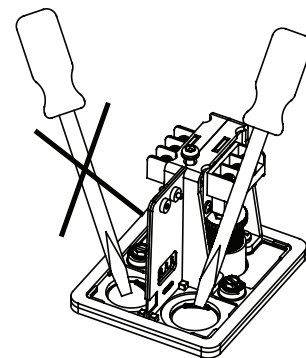

Manufactured by Potter who hold FM Approval, UL Listing, LPCB, VdS and CE Certificates

DS: 2.33

Issue A

05/05/2021

© 2021 Potter

Rapidrop Global Ltd

T: +44 (0) 1733 847 510 F: +44 (0) 1733 553 958

e: rapidrop@rapidrop.com