



Outside Screw and Yoke Valve Supervisory Switch Model: OSYSU-1 & OSYSU-2

Product Description

The OSYSU is used to monitor the open position of an OS&Y (outside screw and yoke) type gate valve. This device is available in two models; the OSYSU-1, containing one set of SPDT (Form C) contacts and the OSYSU-2, containing two sets of SPDT (Form C) contacts. These switches mount conveniently to most OS&Y valves ranging in size from 2" to 12" (50mm to 300mm). They will mount on some valves as small as 1/2" (12,5mm).

The cover is held in place by two tamper resistant screws that require a special tool to remove. The tool is furnished with each device.

Features

- NEMA 4X* and 6P (IP 67)
- *Enclosure is 4X. For additional corrosion protection of mounting hardware, use model OSYSU-2 CRH
- -40°C to 60°C (-40°F to 140°F) operating temperature range
- Visual switch indicators
- Two conduit entrances
- Adjustable length trip rod
- Accommodates up to 12AWG wire
- Three position switch detects tampering and valve closure
- Knurled mounting bracket prevents slipping
- Fine adjustment feature for fast, easy installation
- RoHS compliant
- Model OSYSU-1 one SPDT contact or model OSYSU-2 two SPDT contacts

Testing

The operation of the OSYSU and its associated protective monitoring system shall be inspected, tested, and maintained in accordance with all applicable local and national codes and standards and/or the Authority Having Jurisdiction (manufacturer recommends quarterly or more frequently). A minimum test shall consist of turning the valve wheel towards the closed position. The OSYSU shall operate within the first two revolutions of the wheel. Fully close the valve and ensure that the OSYSU does not restore. Fully open the valve and ensure that the OSYSU restores to normal only when the valve is fully opened.

Notice

Before any work is done on the fire sprinkler or fire alarm system, the building owner or their authorized representative shall be notified. Before opening any closed valve, ensure that opening the valve will not cause any damage from water flow due to open or missing sprinklers, piping, etc.

Caution

Close the valve fully to determine that the stem threads do not activate the switch. The switch being activated by the stem threads could result in a false valve open indication.

Manufactured by Potter who hold FM Approval, UL Listing and CE Certificate



Technical Details

Enclosure	Cover: Die Cast Finish: Red Powder Coat Base: Die Cast Finish: Black Powder Coat All parts have corrosion resistant finishes
Cover Tamper	Tamper Resistant Screws Optional Cover Tamper Switch Available
Contact Ratings	OSYSU-1: One Set of SPDT (Form C) OSYSU-2: Two Sets of SPDT (Form C) 10.0 Amps at 125/250 VAC 2.0 Amps at 30VDC Resistive 10 mAmps minimum at 24 VDC
Environmental Limitations	-40°C to 60°C (-40° F to 140°F) NEMA 4X and NEMA 6P (IP 67) Enclosure (Use suitably rated conduit and connector) Indoor or Outdoor Use
Conduit Entrances	Two Knockouts for 1/2" conduit provided (See Fig. 9 on Page 5 and Notice on Page 6)
Service Use	Automatic Sprinkler - NFPA-13 One or two family dwelling - NFPA-13D Residential occupancy up to four stories - NFPA-13R National Fire Alarm Code - NFPA-72
Weight	0.73 kg (1.6 lbs)



Outside Screw and Yoke Valve Supervisory Switch Model: OSYSU-1 & OSYSU-2

Theory of Operation

The OSYSU is a 3 position switch. The center position is the normal installation position. Normal is when the switch is installed on the OS&Y valve, the valve is fully open and the trip rod of the OSYSU is in the groove of the valve stem. Closing the valve causes the trip rod to ride up out of the groove and activates the switches. Removing the OSYSU from the valve causes the spring to pull the trip rod in the other direction and activates the switches.

Visual Switch Status Indication

There are 3 visual indicators to determine the status of the switches.

Fig 1; the actuator button of the micro switches are on the raised section of the switch actuator.

Fig 2; the trip rod is perpendicular to the base and lined up with the alignment mark on the mounting bracket.

Fig 3; the white visual indicator is visible through the window on the back of the switch actuator.

A final test is to meter the contacts marked COM and N.O. to ensure they are an open circuit when the valve is open and that they close and have continuity within 2 revolutions of turning the valve handwheel towards the closed position and the contacts remain closed as the valve is completely closed and until the valve is completely opened when the trip rod drops back into the groove in the valve stem.

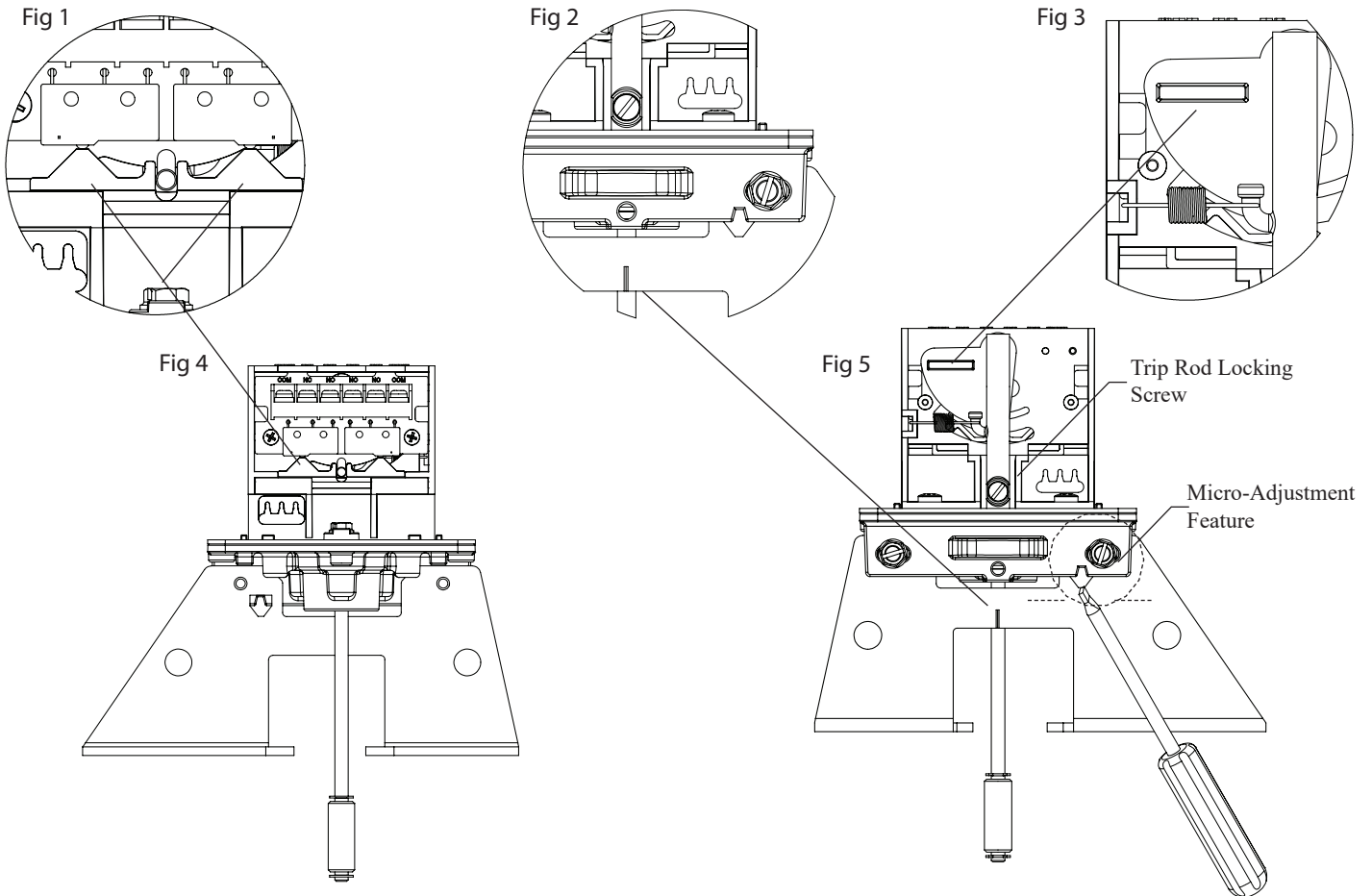

Manufactured by Potter who hold FM Approval, UL Listing and CE Certificate

DS: 2.30
Issue A
05/05/2021
© 2021 Potter

Rapidrop Global Ltd
T: +44 (0) 1733 847 510 F: +44 (0) 1733 553 958
e: rapidrop@rapidrop.com



Outside Screw and Yoke Valve Supervisory Switch Model: OSYSU-1 & OSYSU-2

Small Valve Installation - 1/2" Through 2 1/2" Sizes

Fig 6

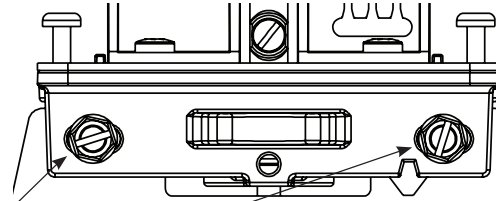
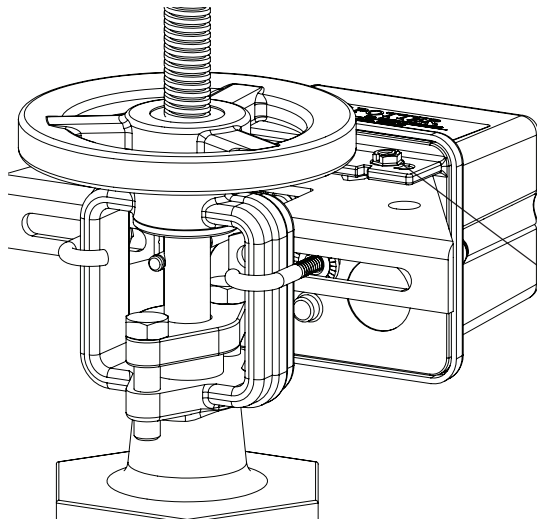

Slotted mounting holes and micro-adjustment feature may be used for fine adjustment of switch assembly to mounting bracket
Re-tighten screws to 20 in-lbs minimum

Small Valve Installation

Note: If the valve stem is pre-grooved at 1/8" minimum depth; proceed to step 7.

1. Remove and discard "E" ring and roller from the trip rod.
2. With the valve in the FULL OPEN position, locate the OSYSU across the valve yoke as far as possible from the valve gland so that the spring loaded trip rod of the OSYSU is pulled against the non threaded portion of the valve stem. Position the OSYSU with the bracket near the handwheel as shown in Fig. 6 if possible to avoid creating a pinch point between the wheel and the OSYSU.
3. Loosen the locking screw that holds the trip rod in place and adjust the rod length (see Fig. 5). When adjusted properly, the rod should extend past the valve screw, but not so far that it contacts the clamp bar. Tighten the locking screw to 5 in-lbs minimum to hold the trip rod in place and properly seal the enclosure.
Note: If trip rod length is excessive, loosen the locking screw and remove the trip rod from the trip lever. Using pliers, break off the one (1) inch long notched section (see Fig. 10). Reinstall trip rod and repeat Step 3 procedure.
4. Mount the OSYSU loosely with the carriage bolts and clamp bar supplied. On valves with limited clearance use J-hooks supplied instead of the carriage bolts and clamp bar to mount the OSYSU.
5. Mark the valve stem at the center of the trip rod.
6. Remove the OSYSU. Utilizing a 3/16" or 1/4" diameter straight file, file a 1/8" minimum depth groove centered on the mark on the valve stem. Deburr and smooth the edges of the groove to prevent damage to the valve packing and to allow the trip rod to move easily in and out of the groove as the valve is operated.
Note: A groove depth of up to approximately 3/16" can make it easier to install the OSYSU so that it does not restore as it rolls over by the threads of the valve stem.

7. Mount the OSYSU on the valve yoke with the spring loaded trip rod of the OSYSU pulled against the valve stem and centered in the groove of the stem. If possible, position the OSYSU with the flat side of the bracket toward the hand wheel, as shown in Fig. 6, to help avoid creating a pinch point between the wheel and OSYSU. When in this preferred mounting position, it is usually best to use the white indicator visible through the window, as illustrated in Fig. 3, to aid in initially locating the OSYSU in the correct position on the yoke. If the unit must be installed inverted with the white indicator no longer easily visible, use the visual indicators of the actuator buttons on the micro-switches, as illustrated in Fig. 1, or the trip rod alignment mark on the bracket, as illustrated in Fig. 2, to aid in initially locating the OSYSU.
8. Final adjustment can be made by slightly loosening the two screws on the bracket and using the fine adjustment feature (see Fig. 5). The adjustment is correct when the plungers on the switches are depressed by the actuator and there is no continuity between the COM and NO terminals on the switches.
9. Tighten the adjustment screws and all mounting hardware securely (20 in-lbs minimum). Check to insure that the rod moves out of the groove easily and that the switches activate within two turns when the valve is operated from the FULL OPEN towards the CLOSED position.
10. Reinstall the cover and tighten the cover screws to 15 in-lbs minimum to properly seal the enclosure.

Caution

Close the valve fully to determine that the stem threads do not activate the switch. The switch being activated by the stem threads could result in a false valve open indication.

Manufactured by Potter who hold FM Approval, UL Listing and CE Certificate

DS: 2.30
Issue A
05/05/2021

Rapidrop Global Ltd
T: +44 (0) 1733 847 510 F: +44 (0) 1733 553 958
e: rapidrop@rapidrop.com



Outside Screw and Yoke Valve Supervisory Switch Model: OSYSU-1 & OSYSU-2

Fig 7

Large Valve Installation - 3" Through 12" Sizes

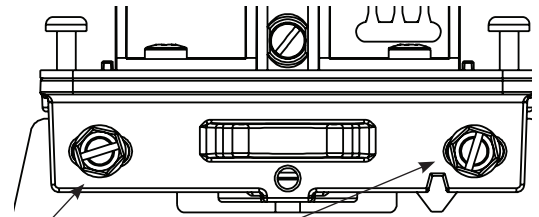
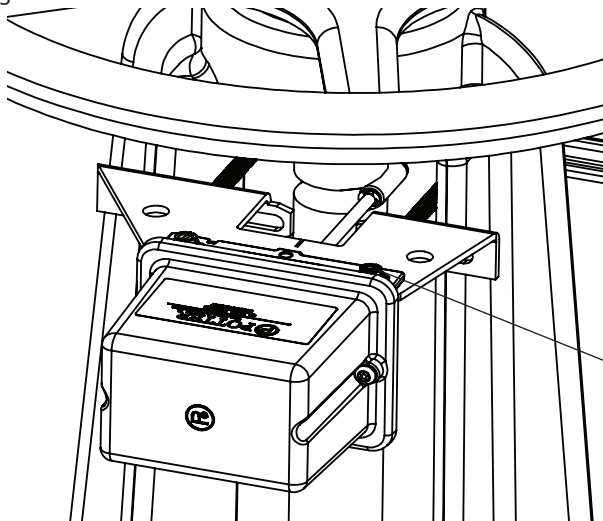

Slotted mounting holes and micro-adjustment feature may be used for fine adjustment of switch assembly to mounting bracket. Re-tighten screws to 20 in-lbs minimum.

Small Valve Installation

Note: If the valve stem is pre-grooved at 1/8" minimum depth; proceed to step 6.

1. With the valve in the FULL OPEN position, locate the OSYSU across the valve yoke as far from the valve gland as possible so that the spring loaded trip rod of the OSYSU is pulled against the non threaded portion of the valve stem. Position the OSYSU with the bracket near the handwheel as shown in Fig. 7 if possible to avoid creating a pinch point between the wheel and the OSYSU.
2. Mount the OSYSU loosely with the carriage bolts and clamp bar supplied.
3. Loosen the locking screw that holds the trip rod in place and adjust the rod length (see Fig. 5). When adjusted properly, the rod should extend past the valve screw, but not so far that it contacts the clamp bar. Tighten the locking screw to 5 in-lbs minimum to hold the trip rod in place and properly seal the enclosure.
Note: If trip rod length is excessive, loosen the locking screw and remove the trip rod from the trip lever. Using pliers, break off the one (1) inch long notched section (see Fig. 10). Reinstall trip rod and repeat Step 3 procedure.
4. Mark the valve stem at the center of the trip rod.
5. Remove the OSYSU. Utilizing a 3/8" or 1/2" diameter straight file, file a 1/8" minimum depth groove centered on the mark on the valve stem. Deburr and smooth the edges of the groove to prevent damage to the valve packing and to allow the trip rod to move easily in and out of the groove as the valve is operated.
Note: A groove depth of up to approximately 3/16" can make it easier to install the OSYSU so that it does not restore as it rolls over by the threads of the valve stem.

6. Mount the OSYSU on the valve yoke with the spring loaded trip rod of the OSYSU pulled against the valve stem and centered in the groove of the stem. If possible, position the OSYSU with the flat side of the bracket toward the hand wheel, as shown in Fig. 7, to help avoid creating a pinch point between the wheel and OSYSU. When in this preferred mounting position, it is usually best to use the white indicator visible through the window, as illustrated in Fig. 3, to aid in initially locating the OSYSU in the correct position on the yoke. If the unit must be installed inverted with the white indicator no longer easily visible, use the visual indicators of the actuator buttons on the micro-switches, as illustrated in Fig. 1, or the trip rod alignment mark on the bracket, as illustrated in Fig. 2, to aid in initially locating the OSYSU.
7. Final adjustment can be made by slightly loosening the two screws on the bracket and using the fine adjustment feature (see Fig. 5). The adjustment is correct when the plungers on the switches are depressed by the actuator and there is no continuity between the COM and NO terminals on the switches.
8. Tighten the adjustment screws and mounting hardware securely (minimum 20 in-lbs). Check to insure that the rod moves out of the groove easily and that the switches activate within two turns when the valve is operated from the FULL OPEN towards the CLOSED position.
9. Reinstall the cover and tighten the cover screws to 15 in-lbs minimum to properly seal the enclosure.

Caution

Close the valve fully to determine that the stem threads do not activate the switch. The switch being activated by the stem threads could result in a false valve open indication.



Outside Screw and Yoke Valve Supervisory Switch Model: OSYSU-1 & OSYSU-2

Dimensions

Fig 8

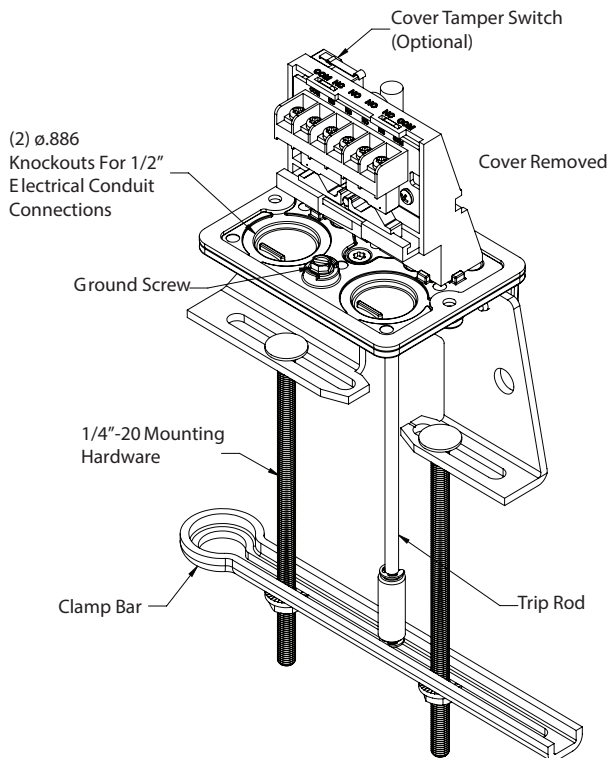
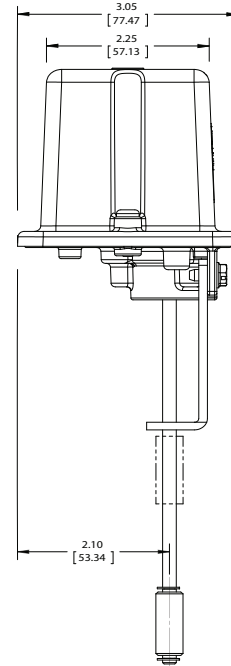
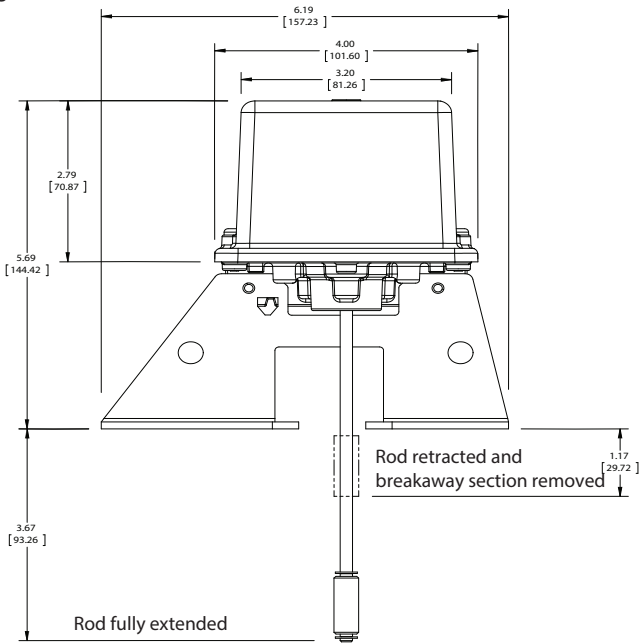

Knockout Removal

Fig 9

To remove knockouts: Place screwdriver at inside edge of knockouts, not in the center.

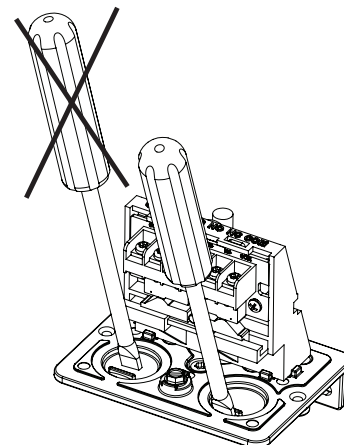

NOTE: Do not drill into the base as this creates metal shavings which can create electrical hazards and damage the device. Drilling voids the warranty.

Manufactured by Potter who hold FM Approval, UL Listing and CE Certificate

DS: 2.30
Issue A
05/05/2021
© 2021 Potter

Rapidrop Global Ltd
T: +44 (0) 1733 847 510 F: +44 (0) 1733 553 958
e: rapidrop@rapidrop.com



Outside Screw and Yoke Valve Supervisory Switch Model: OSYSU-1 & OSYSU-2

Breaking Excessive Rod Length

Fig 10

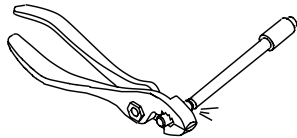

Switch Terminal Connections, Clamping Plate Terminal

Fig 11

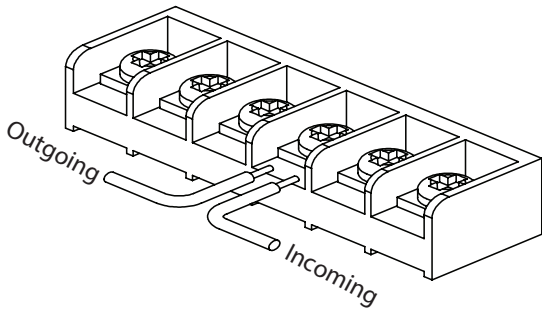

Typical Electrical Connections

Fig 12

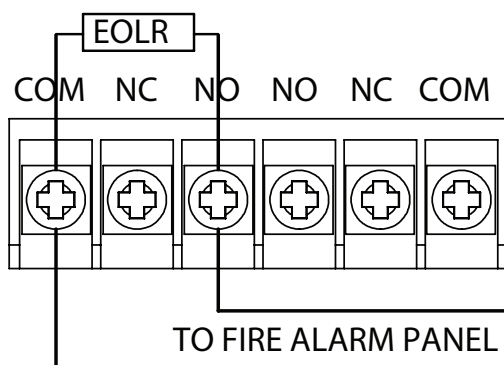

Warning

An uninsulated section of a single conductor should not be looped around the terminal and serve as two separate connections. The wire must be severed, thereby providing supervision of the connection in the event that the wire become dislodged from under the terminal. Failure to sever the wire may render the device inoperable risking severe property damage and loss of life. Do not strip wire beyond 3/8" of length or expose an uninsulated conductor beyond the edge of the terminal block. When using stranded wire, capture all strands under the clamping plate.

Notice

All conduit and connectors selected for the installation of this product shall be suitable for the environment for which it is to be used and shall be installed to the manufacturer's installation instructions. For NEMA 4, 4X, 6, 6P installations, the cover screws are recommended to be tightened to 15 inlbs minimum and the trip rod locking screw tightened to 5 in-lbs minimum to properly seal the enclosure.