



Deluge Valve - Model A

UL Listed

TECHNICAL DATA :	
MODEL	A
NOMINAL SIZE	200, 150, 100, 80 & 50NB
MAXIMUM SERVICE PRESSURE	12 Bar (175 psi)
THREADED OPENING	BSPT
MOUNTING	90° pattern inlet to outlet vertical mounting.
FACTORY HYDROSTATIC TEST PRESSURE	25 Kg./sq.cm. (350 psi)
FLANGE CONNECTION	ANSI B 16.1 FF #125
TRIM	Galvanized steel with brass valves
RECOMMENDED FLOW RATE	200NB - 300 to 1150 m ³ /hr 150NB - 170 to 650 m ³ /hr 100NB - 50 to 225 m ³ /hr 80NB - 30 to 110 m ³ /hr 50NB - 10 to 55 m ³ /hr
FRictional LOSS IN TERMS OF EQUIVALENT LENGTH OF PIPE (C-120)	200NB - 26.00 metres 150NB - 19.00 metres 100NB - 11.00 metres 80NB - 5.50 metres 50NB - 1.80 metres
WET PILOT SPRINKLER HEIGHT LIMITATION	As per graph in the catalogue.
NET WEIGHT WITHOUT TRIM	200NB - 214 Kg. 150NB - 136 Kg. 100NB - 76 Kg. 80NB - 52 Kg. 50NB - 47 Kg.
FINISH	Fire red PU painted.
APPROVAL	UL listed.
ORDERING INFORMATION	Size of valve, flange connection and trim details.



Deluge Valve is known as a system control valve in a deluge system, used for fast application of water in a spray system. Deluge valve protects areas such as power transformer installation, storage tank, conveyor protection and other industrial application etc. With the addition of foaming agent they do protect aircraft hanger and inflammable liquid fire.

VALVE OPERATION

Deluge valve is a quick release, hydraulically operated diaphragm valve. It has three chambers, isolated from each other by the diaphragm operated clapper and seat seal. While in 'SET' position, water pressure is transmitted through an external bypass check valve and restriction orifice from the system supply side to the top chamber, so that supply pressure in the top chamber acts across the diaphragm operated clapper which holds the seat against the inlet supply pressure because of differential pressure design. On detection of fire the top chamber is vented to atmosphere through the outlet port via opened actuation device(s). The top chamber pressure cannot be replenished through the restricted inlet port, thus it reaches less than half the supply pressure instantaneously and the upward force of the supply pressure lifts the clapper allowing water to enter the system piping network and alarm devices.

TRIM DESCRIPTION

a) BASIC TRIM

The basic trim is required on deluge valve regardless of the release system. It contains those components which are required in all types of installation, such as the main drain valve, priming connection, drip check valve, emergency release valve and pressure gauges.



Deluge Valve - Model A

UL Listed

b) DRY PILOT TRIM (PNEUMATIC RELEASE)

Dry pilot operation uses a pilot line of closed Sprinklers/ QB detectors containing air under pressure, located in the area to be protected. It requires regulated dry air supply with main supply point through restricted orifice. The pilot line is connected directly to the top of POSITIVE DRAIN ACTUATOR (PDA). The bottom of PDA is connected to the top chamber of the deluge valve.

When the air pressure drops, due to release of any of the release devices on detection of fire, the diaphragm of PDA is lifted and allows the water to drain. This reduces the water pressure in the top chamber of the deluge valve and when the pressure in the top chamber reaches 50% of the supply pressure, the deluge valve opens. The direct drain of PDA start when the top chamber pressure of deluge valve reaches approximately 0.5 Kg/sq.cm. This positive drain will not permit the deluge valve to close unless the PDA is set manually. The recommended air supply pressure is as per TABLE-1.

TABLE - 1

LINE WATER PRESSURE Kg./ Sq.cm. MAXIMUM	AIR PRESSURE IN DETECTION LINE Kg./ Sq.cm.	
	MINIMUM	MAXIMUM
2	1.2	3.0
4	1.5	3.0
6	2.0	3.5
8	2.5	3.5
10	3.0	3.5
12	3.5	4.0

c) WET PILOT TRIM (HYDRAULIC RELEASE)

Wet pilot operation uses a pilot line of closed sprinklers containing pressurised water, supplied through the upstream side of the deluge valve, through a restricted orifice. All the release lines are connected to a common release line. Due to release of any one of the release devices, the water pressure in the top chamber of the deluge valve reaches 50% of the supply pressure, the deluge valve opens.

CAUTION

While using a deluge valve in the wet pilot system the height and the length of the wet pilot detection line is to be limited as given in the wet pilot sprinkler height limitation graph.

d) ELECTRIC RELEASE TRIM

To actuate a deluge valve electrically, a solenoid valve is provided to drain the water from the top chamber of the deluge valve. A pressure switch is provided to activate an electric alarm, to shut down the desired equipment

or to give "Tripped" indication to the panel. In addition to this two nos of pressure switches can be used to monitor "Low air pressure" and "Fire condition" when used in dry pilot air line.

e) TEST AND ALARM TRIM WITH SPRINKLER ALARM

This trim is supplied with the sprinkler alarm bell, which bells on actuation of the deluge valve. A test valve is provided to test the normal operation of the sprinkler alarm bell.

RESETTING PROCEDURE FOR THE DELUGE VALVE

- (i) Close the upstream side stop valve provided below the deluge valve.
- (ii) Open both the drain valves and close them when the flow of water has ceased.
- (iii) Inspect and release if required, or close the section of the detection system subjected to "Fire condition".
- (iv) In case of dry pilot detection system, open the air supply valve to build-up air pressure as shown in TABLE-1. Open the priming valve fully and press hold the knob of PDA till the water pressure gauge indicate full service line pressure, then release the PDA knob. Open the upstream side of the stop valve provided below the deluge valve. No water should flow into the system, this can be checked by depressing the drip check valve knob.

CAUTION

- (a) Do not close the priming valve, down stream and upstream stop valves, while the system is in service.
- (b) The releasing device must be maintained in the open position, when actuated, to prevent the deluge valve from closure.

SYSTEM TESTING PROCEDURE

- (i) Keep the upstream side of the stop valve partially open. Open the upstream side of the drain valve, to maintain a minimum pressure of 3 Kg./sq. cm on the upstream side of the deluge valve. To avoid water damage close the system side stop valve. This valve is to be kept in open position after the testing is completed.
- (ii) Open the system side drain valve of the deluge valve.
- (iii) Let any of the release devices to trip. This will result in a sudden drop of water pressure in the deluge valve top chamber resulting the deluge valve to open. The water flowing through the down stream side drain valve confirms that the deluge valve has actuated, immediately close the upstream side stop valve .

Rapidrop Global





Deluge Valve - Model A

UL Listed

(iv) Once testing is over reset the valve as per procedure given under heading "RESETTING PROCEDURE FOR THE DELUGE VALVE".

INSPECTION AND MAINTENANCE

All the newly installed system piping network must be flushed properly before placing the deluge valve in service.

A qualified and trained person must commission the system. After few initial successful tests an authorised person must be trained to perform inspection and testing of the system. It is recommended to have regular inspection and test run the system as per NFPA guidelines or in accordance with the guideline laid down by the organisation having local jurisdiction.

(i) WARNING

Inspection and testing is to be carried out only by authorised and trained personnel. DO NOT TURN OFF the water supply or close any valve to make repair(s) or test the valve, without placing a roving fire patrol in the area protected by the system. Also inform the local security personnel and central alarm station, so that a false alarm is not signalled.

It is recommended to carry out physical inspection of the system at least twice in a week. The inspection should verify that all the control valves are in proper position as per the system requirement and no damage has taken place to any component.

(ii) NORMAL CONDITION

- (a) All main valves are open and are sealed with tamper proof seal.
- (b) Drain valves must be kept closed.
- (c) No leak or drip is detected from the drip valve.
- (d) All the gauges except the system side water pressure gauge, should show the required pressure.
- (e) There should be no leakage in the system.

(iii) NORMAL CONDITION TEST

- (a) The system should be checked for normal condition at least once a month.
- (b) Test the sprinkler alarm bell or electric alarm by turning the alarm test valve to the test position. The alarm should sound. This test should be carried out at least once in a week.
- (c) Depress the drip valve knob. Significant water accumulation indicates a possible seat leakage.
- (d) Conduct the water flow test as per the procedure of system testing at least once in a month.

(iv) PERIODIC CHECK

Conduct the water flow test by actuating few of the release devices provided in the system. Clean all strainer(s) and priming line restriction. This test is to be carried out at least once in six months.

ABNORMAL CONDITION

(i) ALARM FAILS TO SOUND

- (a) Check for any obstruction in the alarm test line, Ensure that the sprinkler alarm is freely operating.
- (b) If an electric alarm is provided, check the electrical circuitry to the alarm.

(ii) FALSE TRIPS

- (a) Check for clogging in priming line, restriction orifice check valve, priming valve & strainer.
- (b) Leakage in the release system.
- (c) The deluge air panel orifice clogged or low supply pressure.

(iii) LEAKAGE THROUGH THE DELUGE VALVE

- (a) Damaged deluge valve seat or obstruction on the seat face by foreign object.
- (b) Leakage in release system.
- (c) Partly clogged priming line, restriction check valve.
- (d) Low air pressure on release system line or leakage in release system.
- (e) PDA seat leakage due to seat damage or obstruction on seat face by foreign objects (in dry pilot system only)

NOTE

UL listing is valid only when Deluge Valve is installed with trim set as per trim drawing.



Deluge Valve - Model A

UL Listed

DELUGE VALVE MODEL-A SIZE 200 / 150 / 100 / 80 / 50 NB

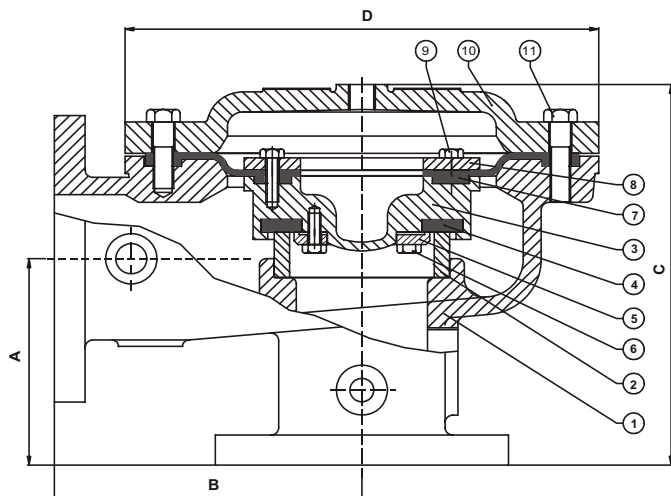

DIMENSION in millimeter (Approximate)

VALVE NOMINAL SIZE	'A'	'B'	'C'	'D'
200NB	230	330	455	540
150 NB	200	300	382	464
100 NB	165	240	304	370
80 NB	135	210	272	316
50 NB	135	210	272	316

PART LIST

ITEM	PART NO.					DESCRIPTION	QTY.					MATERIAL SPECIFICATION
	200 NB	150 NB	100 NB	80 NB	50 NB		200 NB	150 NB	100 NB	80 NB	50 NB	
1	2181	2101	2121	2141	2161	HOUSING	1	1	1	1	1	CAST IRON
2	2187	2107	2127	2147	2147	SEAT	1	1	1	1	1	CAST BRONZE
3	2185	2105	2125	2145	2145	CLAPPER	1	1	1	1	1	CAST BRONZE
4	2189	2109	2129	2149	2149	SEAT RUBBER	1	1	1	1	1	NEOPRENE
5	2190	2110	2130	2150	2150	RUBBER CLAMP	1	1	1	1	1	CAST BRONZE
6	9102	9102	9102	9102	9102	BOLT	6	4	4	3	3	STAINLESS STEEL
7	2188	2108	2128	2148	2148	DIAPHRAGM	1	1	1	1	1	NEOPRENE
8	2186	2106	2126	2146	2146	CLAMP RING	1	1	1	1	1	CAST BRONZE
9	9105	9105	9105	9105	9105	BOLT	12	12	8	8	8	STAINLESS STEEL
10	2184	2104	2124	2144	2144	COVER	1	1	1	1	1	CAST IRON
11	-	-	-	-	-	BOLT	16	16	12	12	12	STEEL





Deluge Valve - Model A

UL Listed

DRY PILOT BASIC TRIM , WITH TEST AND ALARM TRIM & ELECTRIC RELEASE TRIM MODEL -A

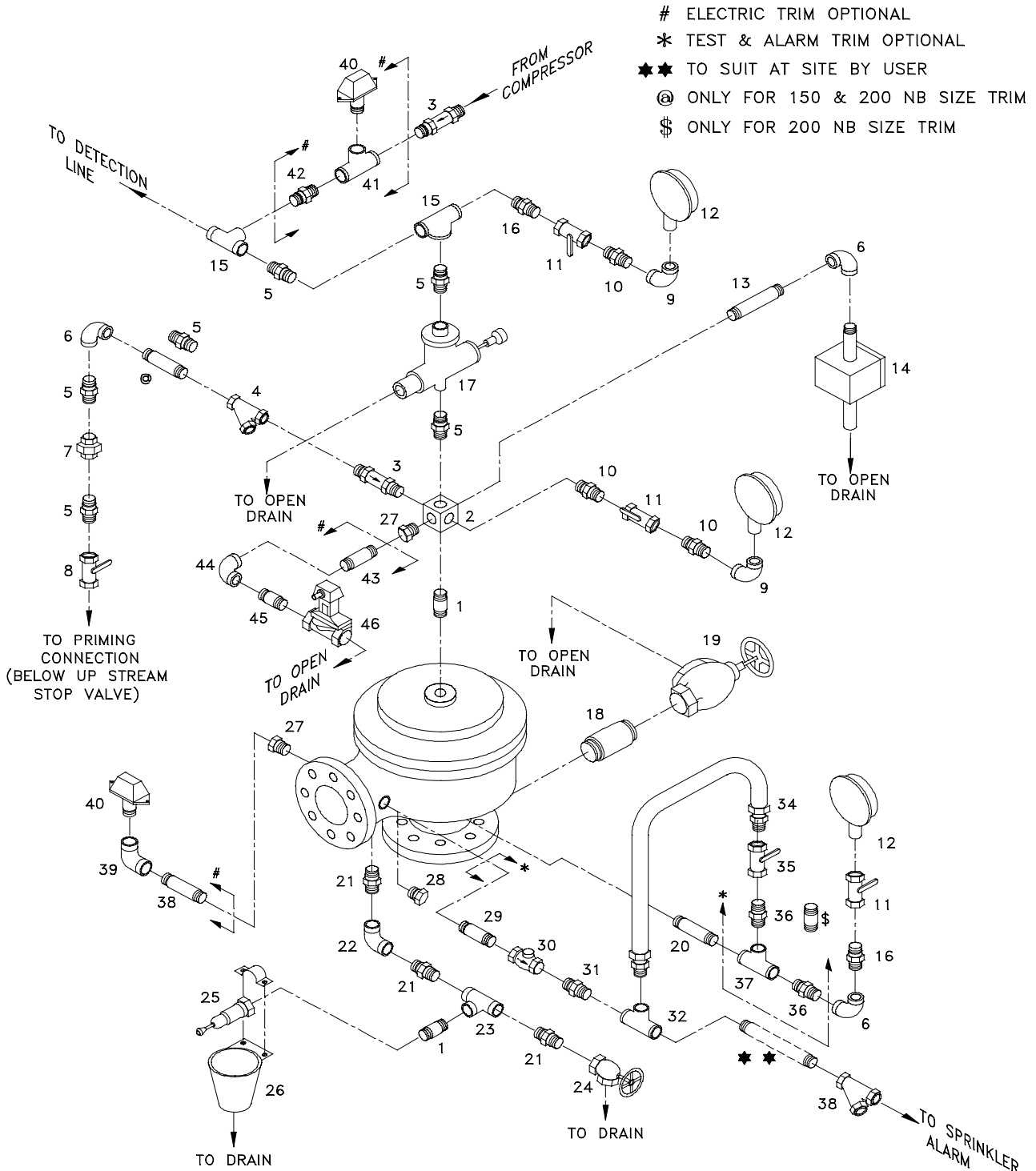

- # ELECTRIC TRIM OPTIONAL
- * TEST & ALARM TRIM OPTIONAL
- ** TO SUIT AT SITE BY USER
- @ ONLY FOR 150 & 200 NB SIZE TRIM
- \$ ONLY FOR 200 NB SIZE TRIM

NOTE : WHEN TEST & ALARM TRIM IS SUPPLIED THEN SL.NO. 28 (PLUG) IS NOT REQUIRED.
WHEN ELECTRIC TRIM IS SUPPLIED THEN SL.NO. 27 (PLUG) IS NOT REQUIRED.

Rapidrop Global





Deluge Valve - Model A

UL Listed

DRY PILOT BASIC TRIM , WITH TEST AND ALARM TRIM & ELECTRIC RELEASE TRIM MODEL -A

TRIM ITEM				QUANTITY PER DELUGE VALVE				
NO	CODE	DESCRIPTION	SIZE	DELUGE VALVE SIZE				
				200NB	150NB	100NB	80NB	50NB
1	9480	PIPE NIPPLE	1/2" X 80 MM LONG	2	2	2	2	2
2	6251	6 WAY MANIFOLD	'RD' MAKE, MODEL-A	1	1	1	1	1
3	1906	RESTRICTION CHECK VALVE	'RD' MAKE, MODEL-A	2	2	2	2	2
4	9381	'Y' TYPE STRAINER	1/2"	1	1	1	1	1
5	9416	PIPE NIPPLE	1/2" X 110 MM LONG	1	1	-	-	-
5	9365	HEX NIPPLE	1/2"	5	5	6	6	6
6	8616	ELBOW	1/2"	3	3	3	3	3
7	8627	UNION	1/2"	1	1	1	1	1
8	9423	BALL VALVE	1/2"	1	1	1	1	1
9	9374	ELBOW	1/4"	2	2	2	2	2
10	9363	HEX NIPPLE	1/4"	3	3	3	3	3
11	9477	GAUGE VALVE	1/4"	3	3	3	3	3
12	9526	PRESSURE GAUGE	'RD' MAKE, MODEL-HDP	3	3	3	3	3
13	9403	PIPE NIPPLE	1/2" X 210 MM LONG	-	-	1	-	-
13	9401	PIPE NIPPLE	1/2" X 180 MM LONG	-	-	-	1	1
13	9564	PIPE NIPPLE	1/2" X 300 MM LONG	1	-	-	-	-
13	9565	PIPE NIPPLE	1/2" X 255 MM LONG	-	1	-	-	-
14	1921	EMERGENCY RELEASE STATION	'RD' MAKE, MODEL-MR	1	1	1	1	1
15	8619	TEE	1/2"	2	2	2	2	2
16	9413	REDUCING HEX NIPPLE	1/2" X 1/4"	2	2	2	2	2
17	1436	POSITIVE DRAIN ACTUATOR	'RD' MAKE, MODEL-A	1	1	1	1	1
18	9566	PIPE NIPPLE	2" X 110 MM LONG	1	1	1	-	-
18	9562	PIPE NIPPLE	1 1/4" X 110 MM LONG	-	-	-	1	1
19	9394	ANGLE VALVE	2"	1	1	1	-	-
19	9392	ANGLE VALVE	1 1/4"	-	-	-	1	1
20	9414	PIPE NIPPLE	1/2" X 150 MM LONG	1	1	-	-	-
20	9399	PIPE NIPPLE	1/2" X 130 MM LONG	-	-	1	1	1
21	9367	HEX NIPPLE	1"	1	1	3	-	-
21	9366	HEX NIPPLE	3/4"	-	-	-	3	3
22	8618	ELBOW	1"	3	3	1	-	-
22	8617	ELBOW	3/4"	-	-	-	1	1
23	8623	REDUCING TEE	1" X 1/2" X 1"	1	1	1	-	-
23	8622	REDUCING TEE	3/4" X 1/2" X 3/4"	-	-	-	1	1
24	9391	ANGLE VALVE	1"	1	1	1	-	-
24	9393	ANGLE VALVE	3/4"	-	-	-	1	1
25	1911	DRIP VALVE	'RD' MAKE, MODEL-A	1	1	1	1	1
26	1901	FUNNEL	'RD' MAKE, MODEL-A	1	1	1	1	1
27	8629	PLUG	1/2"	2	2	2	2	2
28	8630	PLUG	3/4"	1	1	1	1	1





Deluge Valve - Model A

UL Listed

DRY PILOT BASIC TRIM , WITH TEST AND ALARM TRIM & ELECTRIC RELEASE TRIM MODEL -A

TRIM ITEM				QUANTITY PER DELUGE VALVE				
NO	CODE	DESCRIPTION	SIZE	DELUGE VALVE SIZE				
				200NB	150NB	100NB	80NB	50NB
TEST & ALARM TRIM (OPTIONAL)								
29	9406	PIPE NIPPLE	¾" X 100 MM LONG	1	1	1	1	1
30	9421	SWING CHECK VALVE	¾"	1	1	1	1	1
31	9366	HEX NIPPLE	¾"	1	1	1	1	1
32	8622	REDUCING TEE	¾" X ½" X ¾"	1	1	1	1	1
33	9382	'Y' TYPE STRAINER	¾"	1	1	1	1	1
34	2198	COPPER TUBE ASSEMBLY	½"	1	-	-	-	-
34	2119	COPPER TUBE ASSEMBLY	½"	-	1	-	-	-
34	2135	COPPER TUBE ASSEMBLY	½"	-	-	1	-	-
34	2157	COPPER TUBE ASSEMBLY	½"	-	-	-	1	1
35	9423	BALL VALVE	½"	1	1	1	1	1
36	8664	PIPE NIPPLE	½" X 60 MM LONG	1	-	-	-	-
36	9365	HEX NIPPLE	½"	1	2	2	2	2
37	8619	TEE	½"	1	1	1	1	1
ELECTRICAL TRIM FOR PRESSURE SWITCH (OPTIONAL)								
38	9400	PIPE NIPPLE	½" X 135 MM LONG	1	1	1	1	1
39	8616	ELBOW	½"	1	1	1	1	1
40	-	PRESSURE SWITCH *	½"	2	2	2	2	2
41	8619	TEE	½"	1	1	1	1	1
42	9365	HEX NIPPLE	½"	1	1	1	1	1
ELECTRICAL TRIM FOR SOLENOID VALVE (OPTIONAL)								
43	9400	PIPE NIPPLE	½" X 135 MM LONG	-	-	-	2	2
43	9399	PIPE NIPPLE	½" X 130 MM LONG	1	1	1	-	-
44	8616	ELBOW	½"	1	1	1	1	1
45	9401	PIPE NIPPLE	½" X 180 MM LONG	1	1	1	-	-
46	-	SOLENOID VALVE @	½", TWO WAY	1	1	1	1	1

* Specification to be provided at time of ordering..

Pressure switch as optional can be provided for "DV actuated" annunciation, switch to be mounted at the outlet of deluge valve. In dry pilot trim additional pressure switch can be provided for low pressure alarm.

@ 2 way solenoid valve with 24VDC/110 VAC/220 VAC for remote actuation





Deluge Valve - Model A

UL Listed

WET PILOT BASIC TRIM , WITH TEST AND ALARM TRIM & ELECTRIC RELEASE TRIM MODEL -A

- # ELECTRIC TRIM OPTIONAL
- * TEST & ALARM TRIM OPTIONAL
- ★★ TO SUIT AT SITE BY USER
- @ ONLY FOR 150 & 200 NB SIZE
- \$ ONLY FOR 200 NB SIZE TRIM

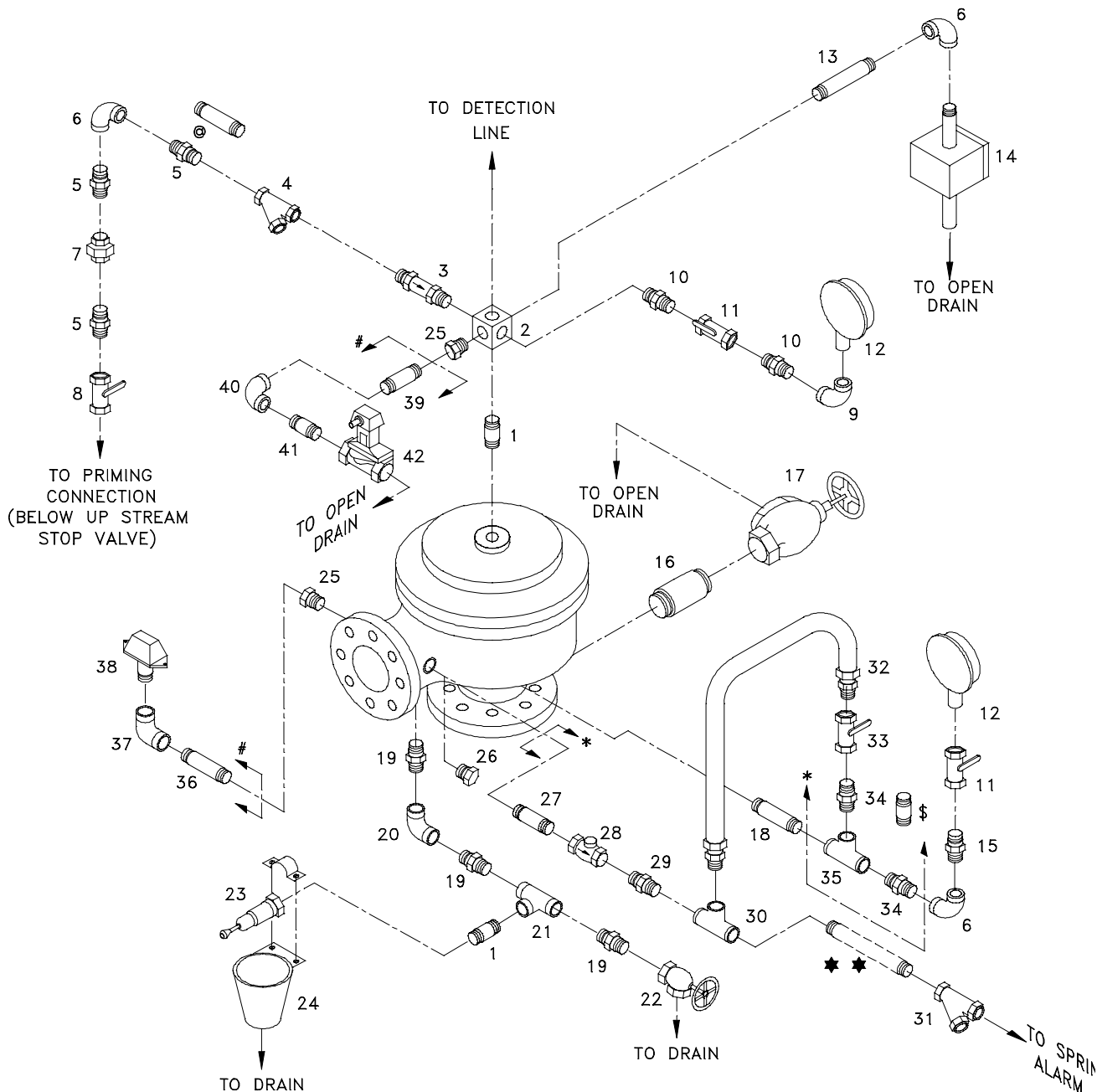

NOTE : WHEN TEST & ALARM TRIM IS SUPPLIED THEN SL.NO. 26 (PLUG) IS NOT REQUIRED.
WHEN ELECTRIC TRIM IS SUPPLIED THEN SL.NO. 25 (PLUG) IS NOT REQUIRED.

Rapidrop Global





Deluge Valve - Model A

UL Listed

WET PILOT BASIC TRIM , WITH TEST AND ALARM TRIM & ELECTRIC RELEASE TRIM MODEL -A

TRIM ITEM				QUANTITY PER DELUGE VALVE				
NO	CODE	DESCRIPTION	SIZE	DELUGE VALVE SIZE				
				200NB	150NB	100NB	80NB	50NB
1	9480	PIPE NIPPLE	1/2" X 80 MM LONG	2	2	2	2	2
2	6251	6 WAY MANIFOLD	'RD' MAKE, MODEL-A	1	1	1	1	1
3	1906	RESTRICTION CHECK VALVE	'RD' MAKE, MODEL-A	1	1	1	1	1
4	9381	'Y' TYPE STRAINER	1/2"	1	1	1	1	1
5	9416	PIPE NIPPLE	1/2" X 110 MM LONG	1	1	-	-	-
5	9365	HEX NIPPLE	1/2"	3	3	4	4	4
6	8616	ELBOW	1/2"	3	3	3	3	3
7	8627	UNION	1/2"	1	1	1	1	1
8	9423	BALL VALVE	1/2"	1	1	1	1	1
9	9374	ELBOW	1/4"	1	1	1	1	1
10	9363	HEX NIPPLE	1/4"	2	2	2	2	2
11	9477	GAUGE VALVE	1/4"	2	2	2	2	2
12	9526	PRESSURE GAUGE	'RD' MAKE, MODEL-HDP	2	2	2	2	2
13	9403	PIPE NIPPLE	1/2" X 210 MM LONG	-	-	1	-	-
13	9401	PIPE NIPPLE	1/2" X180 MM LONG	-	-	-	1	1
13	9564	PIPE NIPPLE	1/2" X 300 MM LONG	1	-	-	-	-
13	9565	PIPE NIPPLE	1/2" X 255 MM LONG	-	1	-	-	-
14	1921	EMERGENCY RELEASE STATION	'RD' MAKE, MODEL-MR	1	1	1	1	1
15	9413	REDUCING HEX NIPPLE	1/2" X 1/4"	1	1	1	1	1
16	9566	PIPE NIPPLE	2" X 110 MM LONG	1	1	1	-	-
16	9562	PIPE NIPPLE	1 1/4" X 110 MM LONG	-	-	-	1	1
17	9394	ANGLE VALVE	2"	1	1	1	-	-
17	9392	ANGLE VALVE	1 1/4"	-	-	-	1	1
18	9414	PIPE NIPPLE	1/2" X 150 MM LONG	1	1	-	-	-
18	9399	PIPE NIPPLE	1/2" X 130 MM LONG	-	-	1	1	1
19	9367	HEX NIPPLE	1"	3	3	3	-	-
19	9366	HEX NIPPLE	3/4"	-	-	-	3	3
20	8618	ELBOW	1"	1	1	1	-	-
20	8617	ELBOW	3/4"	-	-	-	1	1
21	8623	REDUCING TEE	1" X 1/2" X 1"	1	1	1	-	-
21	8622	REDUCING TEE	3/4" X 1/2" X 3/4"	-	-	-	1	1
22	9391	ANGLE VALVE	1"	1	1	1	-	-
22	9393	ANGLE VALVE	3/4"	-	-	-	1	1
23	1911	DRIP VALVE	'RD' MAKE, MODEL-A	1	1	1	1	1
24	1901	FUNNEL	'RD' MAKE, MODEL-A	1	1	1	1	1
25	8629	PLUG	1/2"	2	2	2	2	2
26	8630	PLUG	3/4"	1	1	1	1	1

Rapidrop Global





Deluge Valve - Model A

UL Listed

WET PILOT BASIC TRIM , WITH TEST AND ALARM TRIM & ELECTRIC RELEASE TRIM MODEL -A

TRIM ITEM				QUANTITY PER DELUGE VALVE				
NO	CODE	DESCRIPTION	SIZE	DELUGE VALVE SIZE				
				200NB	150NB	100NB	80NB	50NB
TEST & ALARM TRIM (OPTIONAL)								
27	9406	PIPE NIPPLE	¾" X 100 MM LONG	1	1	1	1	1
28	9421	SWING CHECK VALVE	¾"	1	1	1	1	1
29	9366	HEX NIPPLE	¾"	1	1	1	1	1
30	9411	REDUCING TEE	¾" X ½" X ¾"	1	1	1	1	1
31	8622	'Y' TYPE STRAINER	¾"	1	1	1	1	1
32	2198	COPPER TUBE ASSEMBLY	½"	1	-	-	-	-
32	2119	COPPER TUBE ASSEMBLY	½"	-	1	-	-	-
32	2135	COPPER TUBE ASSEMBLY	½"	-	-	1	-	-
32	2157	COPPER TUBE ASSEMBLY	½"	-	-	-	1	1
33	9423	BALL VALVE	½"	1	1	1	1	1
34	8664	PIPE NIPPLE	½" X 60 MM LONG	1	-	-	-	-
34	9365	HEX NIPPLE	½"	1	2	2	2	2
35	8619	TEE	½"	1	1	1	1	1
ELECTRICAL TRIM FOR PRESSURE SWITCH (OPTIONAL)								
36	9400	PIPE NIPPLE	½" X 135 MM LONG	1	1	1	1	1
37	8616	ELBOW	½"	1	1	1	1	1
38	-	PRESSURE SWITCH *	½"	1	1	1	1	1
ELECTRICAL TRIM FOR SOLENOID VALVE (OPTIONAL)								
39	9400	PIPE NIPPLE	½" X 135 MM LONG	-	-	-	2	2
39	9399	PIPE NIPPLE	½" X 130 MM LONG	1	1	1	-	-
40	8616	ELBOW	½"	1	1	1	1	1
41	9401	PIPE NIPPLE	½" X 180 MM LONG	1	1	1	-	-
42	-	SOLENOID VALVE @	½", TWO WAY	1	1	1	1	1

* Specification to be provided at time of ordering.

Pressure switch as optional can be provided for "DV actuated" annunciation. Pressure switch to be mounted at the outlet of deluge valve.

@ 2 way solenoid valve with 24VDC/110 VAC/220 VAC for remote actuation



ELECTRIC & HYDRAULIC RELEASE TRIM - SCHEMATIC DELUGE VALVE 200 / 150 / 100 / 80 / 50 NB A

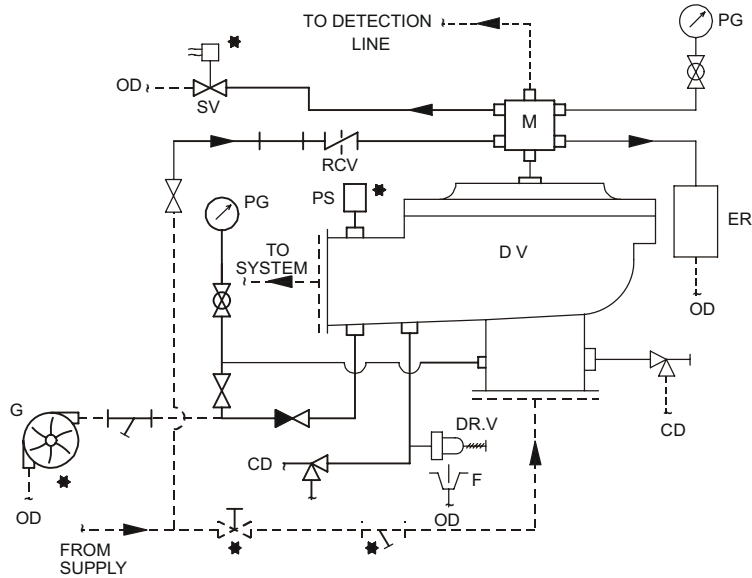

ELECTRIC & PNEUMATIC RELEASE TRIM - SCHEMATIC DELUGE VALVE 200 / 150 / 100 / 80 / 50 NB A

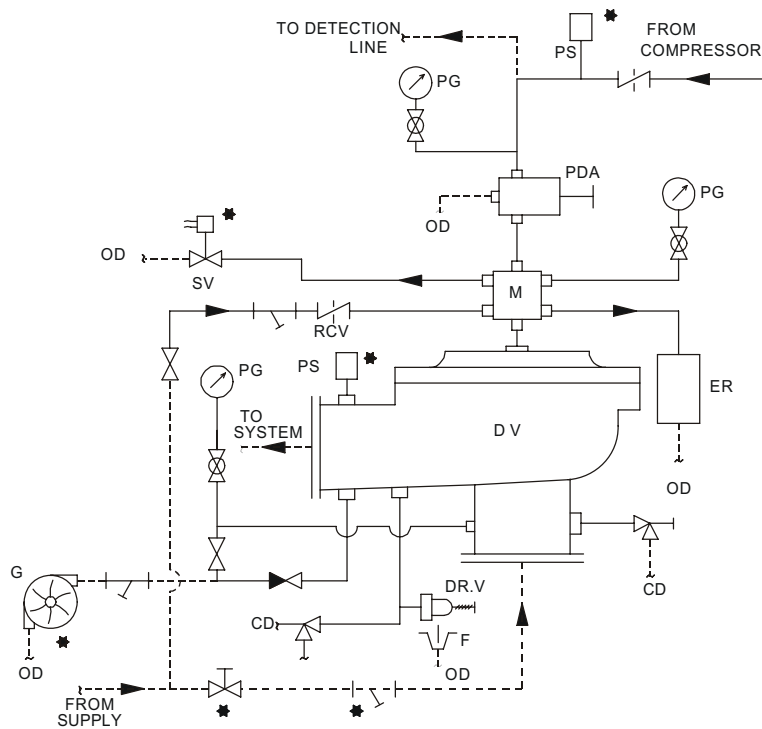

	VALVE		STOP VALVE	DR.V - DRIP VALVE		NON RETURN VALVE
	STRAINER	----	BY USER	CD - COMMON DRAIN	OD - OPEN DRAIN	OD - OPEN DRAIN
	OPTIONAL	SV - SOLONOID VALVE	SV - SOLONOID VALVE	F - FUNNEL	ER - EMERGENCY RELESE BOX	ER - EMERGENCY RELESE BOX
	GAUGE VALVE	PS - PRESSURE SWITCH	PS - PRESSURE SWITCH	DV - DELUGE VALVE	RCV - RESTRICTION CHECK VALVE	RCV - RESTRICTION CHECK VALVE
	ANGLE VALVE	M - SIX WAY MANIFOLD	M - SIX WAY MANIFOLD	PG - PRESSUER GAUGE		

Rapidrop Global



Deluge Valve - Model A

UL Listed

WET PILOT BASIC TRIM , WITH TEST AND ALARM TRIM & ELECTRIC RELEASE TRIM MODEL -A

- # ELECTRIC TRIM OPTIONAL
- * TEST & ALARM TRIM OPTIONAL
- ★★ TO SUIT AT SITE BY USER
- @ ONLY FOR 150 & 200 NB SIZE
- \$ ONLY FOR 200 NB SIZE TRIM

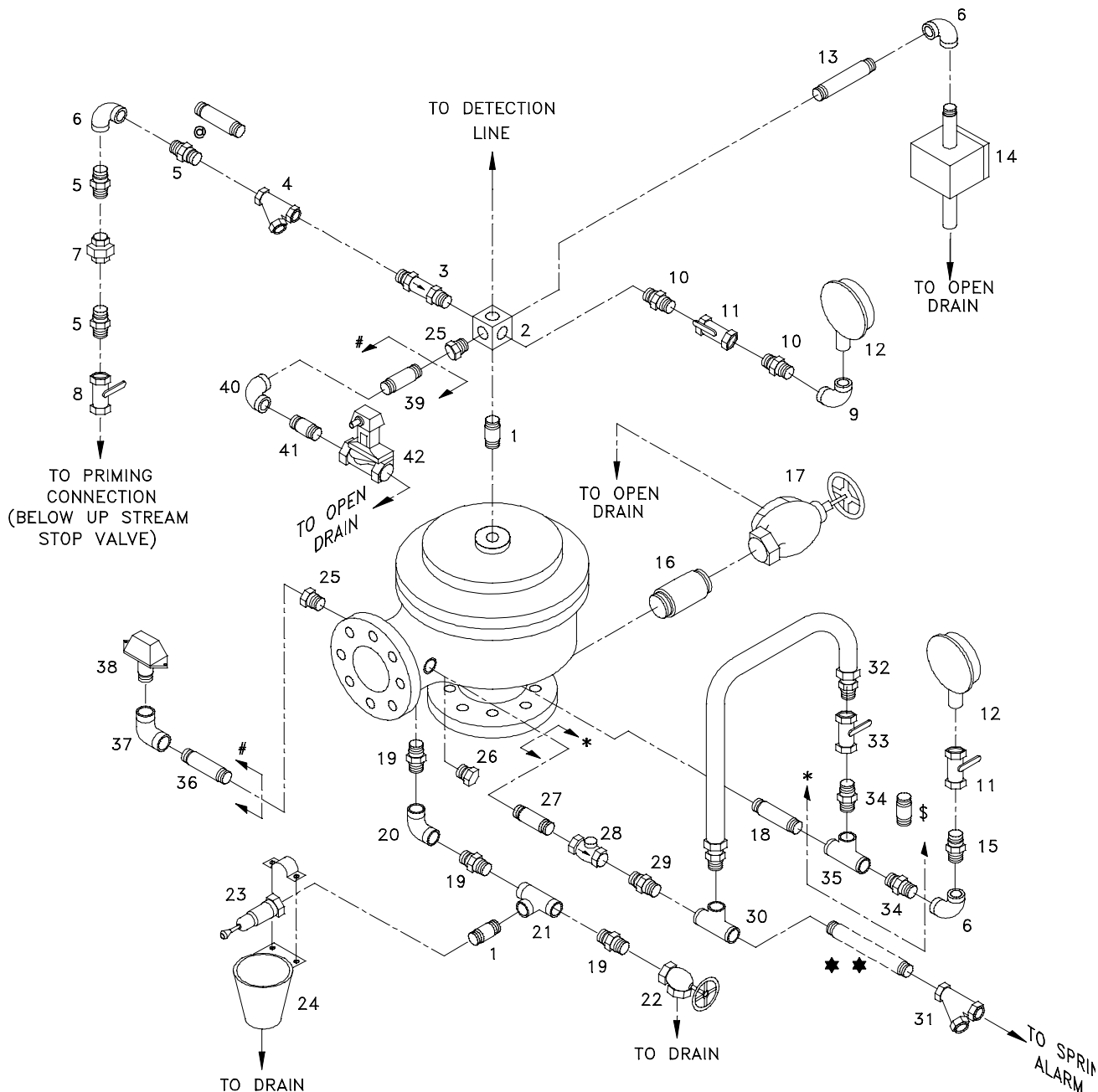

NOTE : WHEN TEST & ALARM TRIM IS SUPPLIED THEN SL.NO. 26 (PLUG) IS NOT REQUIRED.
WHEN ELECTRIC TRIM IS SUPPLIED THEN SL.NO. 25 (PLUG) IS NOT REQUIRED.

Rapidrop Global





Deluge Valve - Model A

UL Listed

WET PILOT SPRINKLER HEIGHT LIMITATION OF 200NB

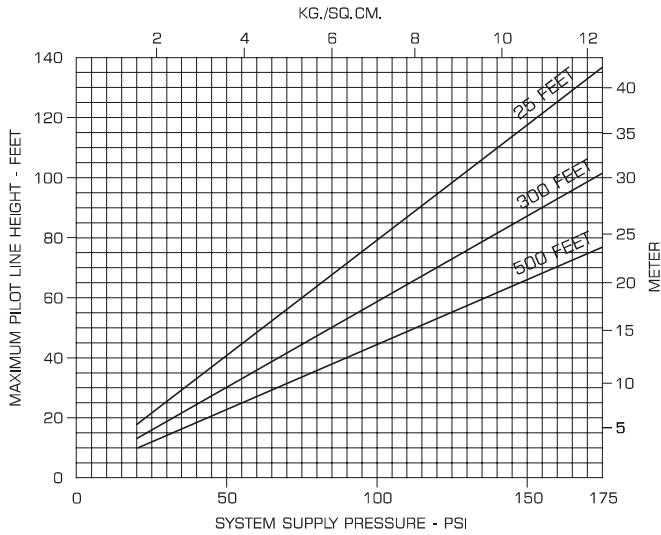

EQUIVALENT LENGTH BASED ON 1/2" SCHEDULE 40 PIPE WITH C = 120

WET PILOT SPRINKLER HEIGHT LIMITATION OF 150NB

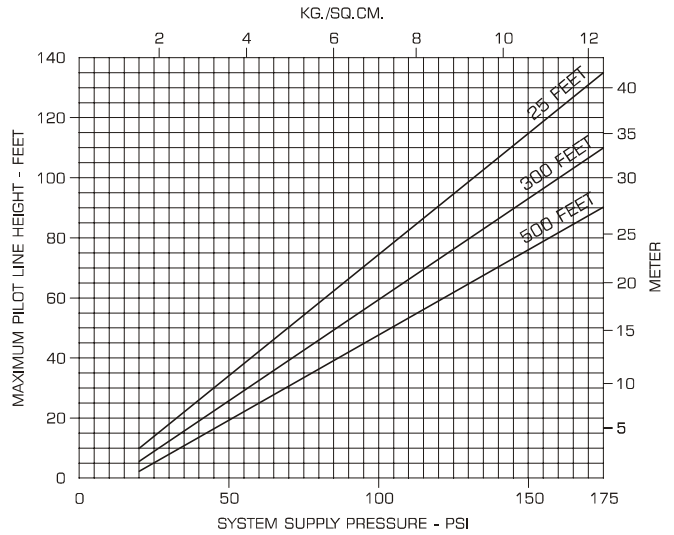

EQUIVALENT LENGTH BASED ON 1/2" SCHEDULE 40 PIPE WITH C = 120

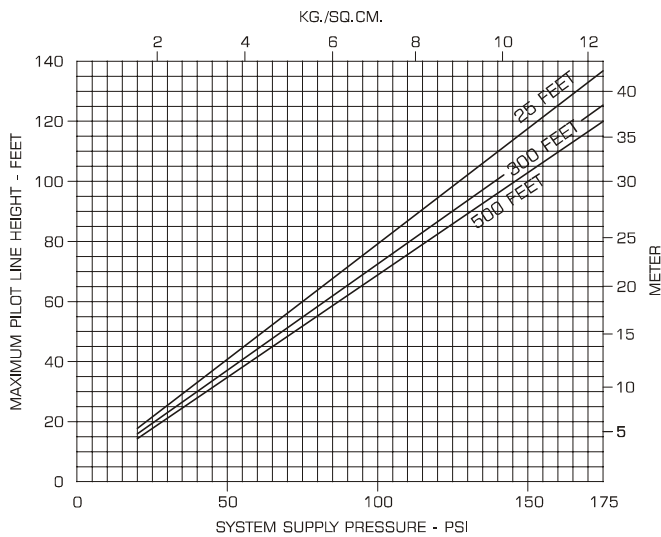

EQUIVALENT LENGTH BASED ON 3/4" SCHEDULE 40 PIPE WITH C = 120

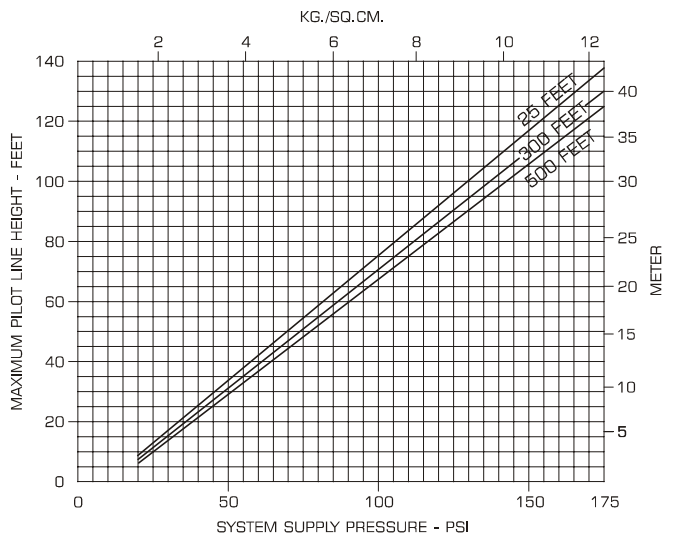

EQUIVALENT LENGTH BASED ON 3/4" SCHEDULE 40 PIPE WITH C = 120





Deluge Valve - Model A

UL Listed

WET PILOT SPRINKLER HEIGHT LIMITATION OF 100NB

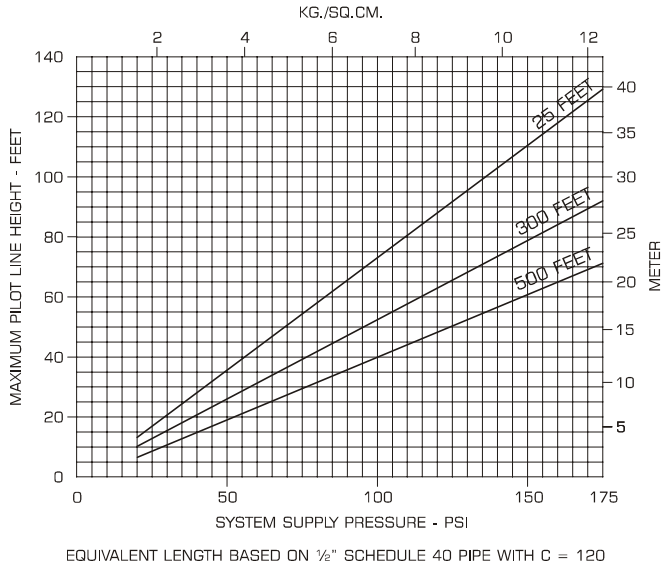

WET PILOT SPRINKLER HEIGHT LIMITATION OF 80NB

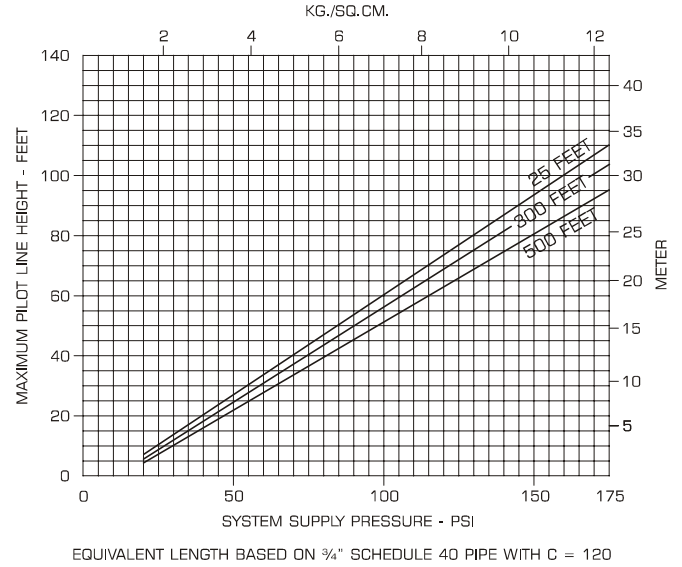
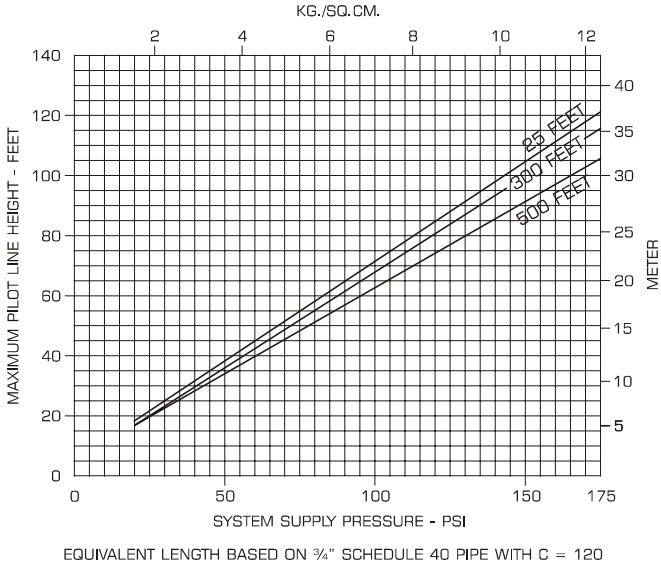
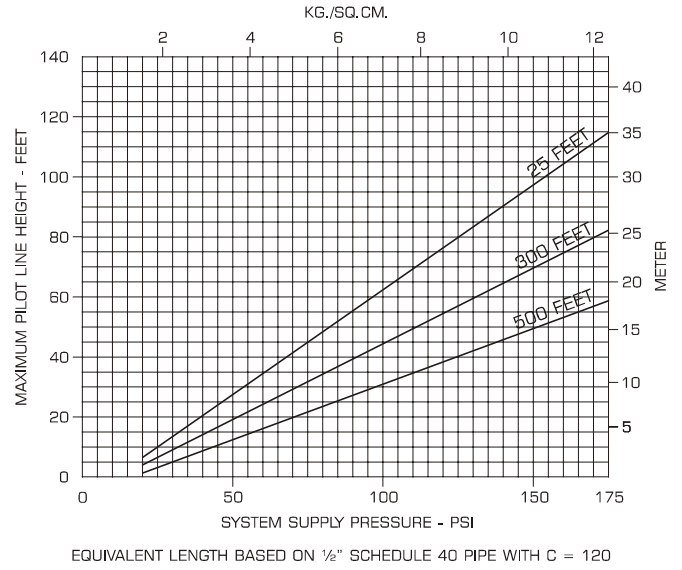

Rapidrop Global



**WET PILOT SPRINKLER
HEIGHT LIMITATION OF 50NB**

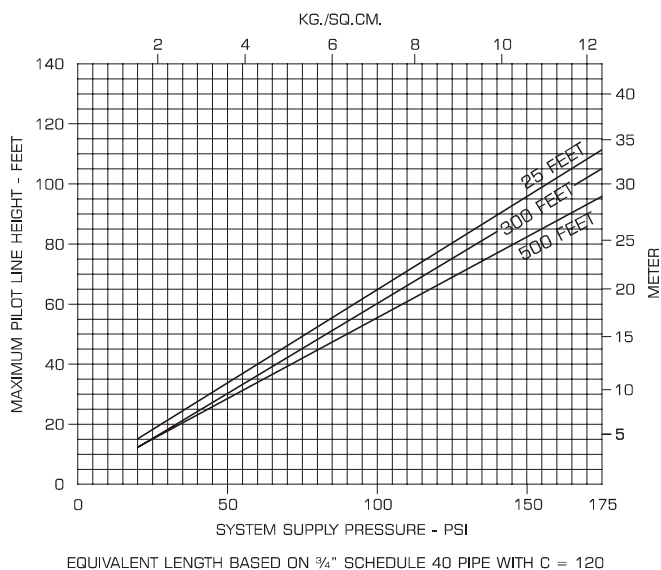
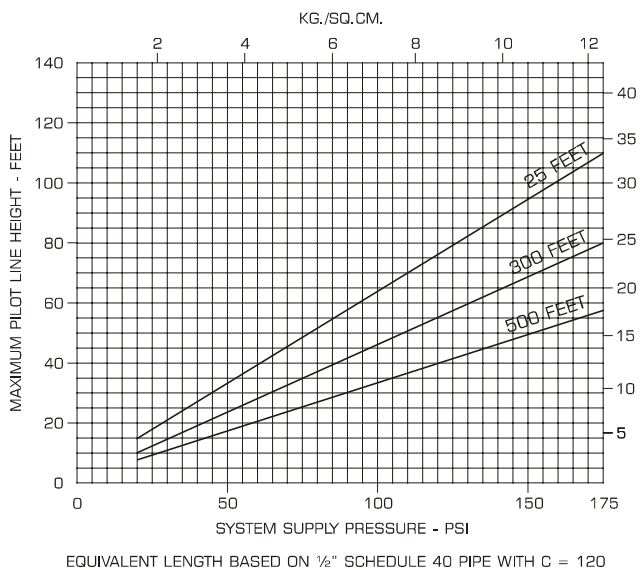

LIMITED WARRANTY

Products supplied by Rapidrop (RD), are warranted against defects in material and workmanship for a period of Two (2) years from the date of shipment. RD's obligation under this warranty is limited to replace or repair the products or its parts, which are shown to RD's examination to be in a defective condition attributable to RD. No warranty is given for products or components which have been subject, to misuse, improper installation, corrosion, wear and tear, improper storage, modification or repaired. If the defect attributable to RD cannot be rectified by repair or replacement, then RD may elect to refund the purchase price of the equipment in complete discharge of its obligation under this Limited Warranty.

IN NO EVENT SHALL RAPIDROP, BE LIABLE IN CONTRACT, STRICT LIABILITY OR ANY OTHER LEGAL THEORY, FOR INCIDENTAL, IN-DIRECT, SPECIAL OR CONSEQUENTIAL DAMAGES, INCLUDING DAMAGES, FOR INJURY TO PERSON OR DEATH OR DAMAGE TO PROPERTY AND OR PENALTIES RESULTING FROM ANY PRODUCTS OR COMPONENT MANUFACTURED OR ASSEMBLED BY RD. THIS IS A LIMITED WARRANTY. RD DISCLAIMS WITH RESPECT TO THE PRODUCTS ALL IMPLIED WARRANTIES OF MERCHANTABILITY AND ALL IMPLIED WARRANTIES OF FITNESS FOR A PARTICULAR PURPOSE. THERE IS NO WARRANTY OF ANY NATURE MADE BY RD BEYOND AS STATED ABOVE.

NOTICE :

The equipment presented in this bulletin is to be installed in accordance with the latest publication standards of NFPA or other similar organisations and also with the provision of government codes or ordinances wherever applicable. The information provided by us are to the best of our knowledge and belief, and are general guidelines only. Site handling and installation control is beyond our reach. Hence we give no guarantee for result and take no liability for damages, loss or penalties whatsoever, resulting from our suggestion, information, recommendation or damages due to our product. Product development is a continuous programme of Rapidrop and hence the right to modify any specification without prior notice is reserved with the company.

Rapidrop Global

