

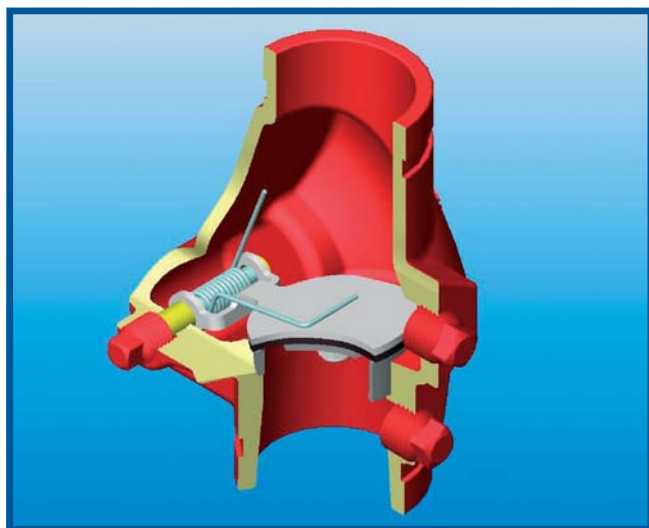

## FCG300 Grooved Swing Check Valve

UL Listed Sizes 2 1/2" to 6" / FM Approved Sizes 2" to 8"



### Description

The Check Valve is a compact, cost effective valve offering low pressure-drop, non-slam performance. The Check Valve assembly is lighter and faster to install than flanged and wafer valve assemblies.

In the full-open position the swing clapper is held tightly against the valve body, out of the flow stream, to provide maximum flow area and prevention of clapper flutter. The clapper design produces quick, non-slam closure before flow reversal can occur, while meeting FM requirements for an anti-water hammer valve rating.

Each valve is hydrostatically tested for leak tightness to 34.5 Bar. The clapper-seat design permits leak free sealing of back pressures in service conditions ranging from 20.7 Bar to as low as 0.35 Bar (710mm water head).

Suitable for installation in horizontal or vertical pipelines. The hinge pin must be above the centreline when mounted horizontally.

### Pressure & Temperature

Max Working Pressure:	20.7 Bar
Max Test Pressure:	34.5 Bar
Max Working Temperature:	120°C

Continued Overleaf  
Page 1 of 2

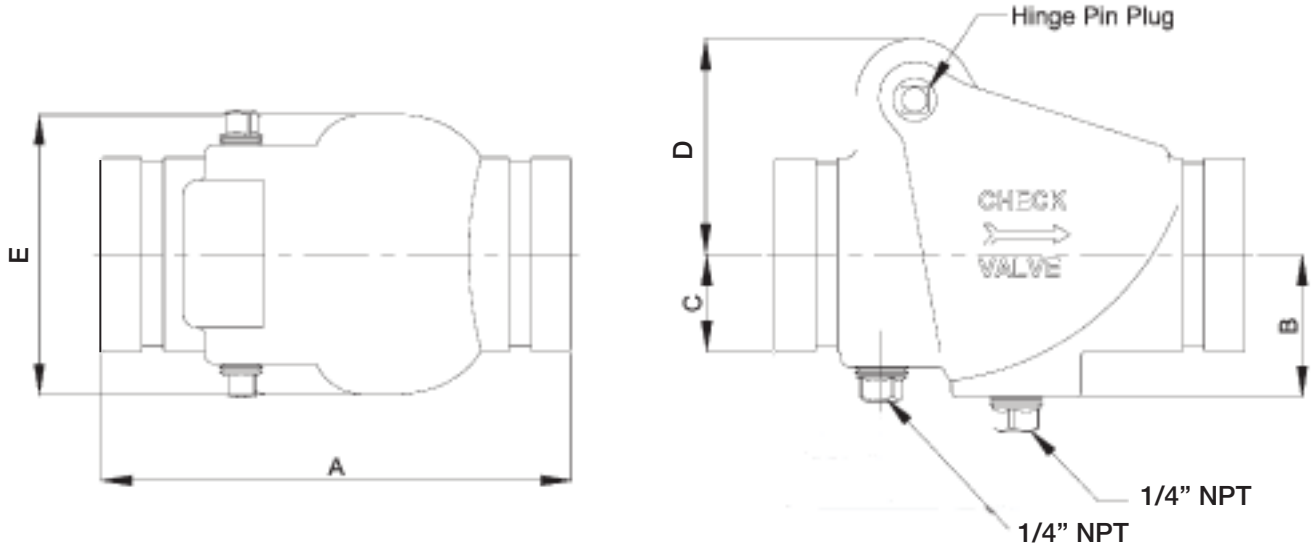

## Dimensions

Size	Pipe O/D mm	A mm	B mm	C mm	D mm	E mm	Wt Kg
2"	60.3	169	60	36	81	111	2.5
2.1/2"	73.0	183	61	39	86	114	5.0
2.1/2"	76.1	183	61	39	86	114	5.0
3"	88.9	198	67	51	93	125	6.0
4"	114.3	218	79	57	108	152	9.0
6"	165.1	270	108	84	171	216	18.0
6"	168.3	270	108	84	171	216	18.0
8"	219.1	325	128	100	203	260	33.0

## Material Specification

Item	Material
Body	Ductile iron conforming to ASTM A 536 Epoxy coated
Colour	Red
Clapper	2" - 5" Type 304 or 302 stainless steel to ASTM A 167 6" - 8" Ductile iron conforming to ASTM A 536, Grade 65-45-12
Clapper Facing	Grade E EPDM - -40°C to 110°C service temperature range housing
Seat Ring	Type 304 stainless steel to ASTM A 123, ASTM A 312, ASTM A 213 or ASTM A 269
Spring	Type 302 stainless steel to ASTM A 313
Hinge Pin	Type 304 or 302 stainless steel to ASTM A 580
Hinge Pin Bushing	Sintered bronze to ASTM B 438
Hinge Pin and Drain Plugs	Cast iron to ASTM A 126 Class A