

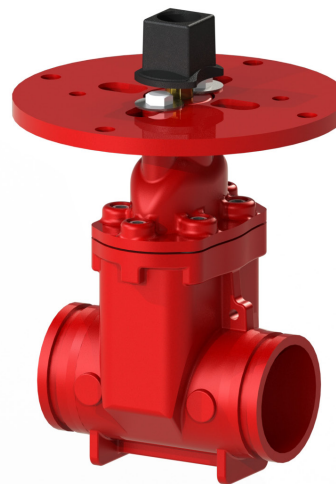

PIV NRS Grooved Gate Valve Fig. 104GG

Product Description

Rapidrop Fig.104GG Valve is a manually operated, non rising stem resilient wedge gate valve designed for use in fire protection systems for on/off operation only. The lightweight ductile iron body allows for easier handling and reduced shipping costs. Valves are suitable for both vertical and horizontal installation. Rapidrop vertical post indicator and Rapidrop wall post indicator, are available separately. Valve components are corrosion resistant or coated with a thermally applied fusion-bonded epoxy. The EPDM encapsulated ductile iron wedge with a compression mechanism is designed to achieve water tight sealing and low torque operation.



Maximum Working Pressure

DN65 - DN250 (2½" - 10") : 20.7 bar (300 PSI)

DN300 - DN400 (12" - 16") : 17.2 bar (250 PSI)

Maximum Working Temperature

71°C / 160°F

Approvals

FM Approved

UL Listed

Coating

Fusion Bonded Epoxy Coating in accordance with ANSI /AWWA C550

Groove Specification

ISO 6182-12/AWWA C606

Design Standard

Conforms to AWWA C509-09

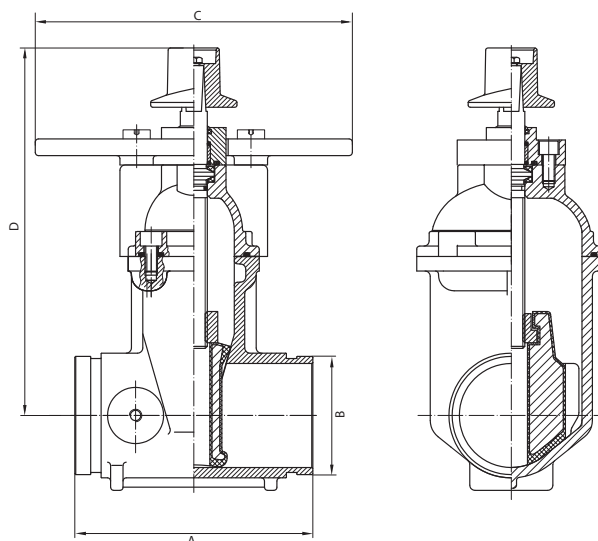

Sizes

SIZES		Dimensions (mm)				Turns to Open	Weight (Kg)	Product Ordering Code
mm	inch	A	B	C	D			
DN 65	2½"	190.5	73.0	305	293	8.8	20	RD104GG065
DN 65	2½"	190.5	76.1	305	293	8.8	20	RD104GG076
DN 80	3"	203	88.9	305	322	10.5	24	RD104GG080
DN 100	4"	229	114.3	305	352	13	43	RD104GGRD100
DN 150	6"	267	165.1	305	445	15.7	70	RD104GG150
DN 150	6"	267	168.3	305	445	15.7	70	RD104GG168
DN 200	8"	292	219.1	305	528	17.2	112	RD104GG200
DN 250	10"	330	273.0	305	617	21.4	159	RD104GG250
DN 300	12"	356	323.9	305	705	25.5	220	RD104GG300
DN 350	14"	381	355.6	305	807	44	322	RD104GG350
DN 400	16"	406	406.4	305	868	50	415	RD104GG400

Note: Ordering codes for European countries.

For other areas please contact your local Rapidrop sales representative.



PIV NRS Grooved Gate Valve Fig. 104GG

Installation

Rapidrop Fig.104GG Grooved Gate Valve is suitable for indoor and outdoor use. The valve should be installed in a location easily accessible for operation and maintenance. The valve may be installed in any position and the flow may be from either direction through the valve. Valves should be supported independently to prevent the movement and stresses from the connecting piping system.

1. Visually inspect the valve, make sure the seating area is not damaged and that the connecting faces are clean of debris and any foreign materials.
2. Ensure that valve is in the closed position during handling and installation process.
3. Using appropriate grooved couplings connect the valve with adjacent pipe or fitting. Follow the instructions supplied by the manufacturer of the couplings.
4. Before pressurising the system make sure the valve is in fully open position.

Care and Maintenance

The valve should never be forced to seat by applying a wrench to the stem as this may distort the valve components. The use of excessive force to open or close the valve violates all warranties.

The valve should not be used to force a pipeline into position as this may result in the damage of the valve components.

Rapidrop gate valves require no regular maintenance, however it is advisable to inspect and verify proper operation of the unit annually or in accordance with the authority having jurisdiction.

The inspection should include a visual check for leakage at the pipe connection. Inspection and maintenance should be performed by a competent person in accordance with national codes/ requirements.

Debris in the piping system might cause difficulties in closing the valve, this problem can be overcome by backing off the wrench/ handwheel and closing the valve again.

Rapidrop Figure 104GG Grooved Gate Valves are suitable for both indoor and outdoor use. Minor degradations of surface finish should not affect the performance of the valve.

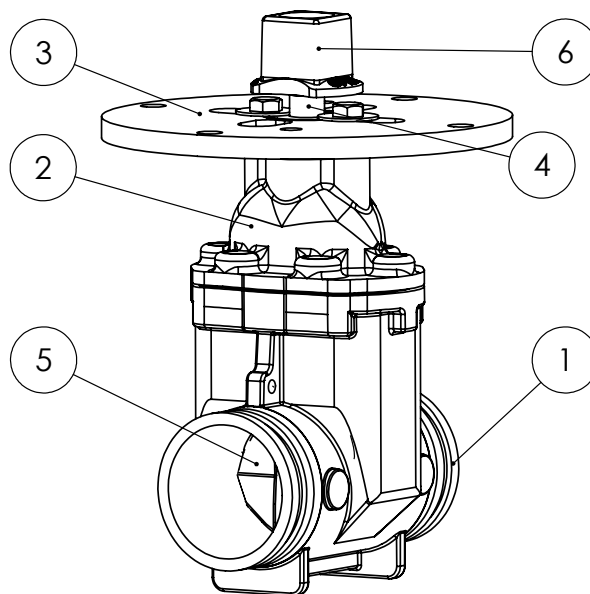

Material Specification

No	Description	Material
1	Valve Body	Ductile Iron ASTM A 536
2	Bonnet	Ductile Iron ASTM A 536
3	Indicator Mounting Flange	Ductile Iron ASTM A 536
4	Stem	Bronze ASTM B 150 UNS C61400 Optional Stainless Steel ASTM A276
5	Resilient Wedge	Ductile Iron ASTM A 536 EPDM ASTM D 2000
6	Drive Nut*	Gray Cast Iron ASTM A 126-B

*Note: 2" Taper square Drive Nut for all valve sizes.

Important Installation Information

- Rapidrop Figure 104GG Grooved Gate Valve must only be installed by a competent person in accordance with requirements of the local authority having jurisdiction. Deviations from these standards will invalidate warranty.
- It is the responsibility of the installing contractor to include a copy of this document in the sprinkler system installation, operating and maintenance manual.
- Alterations to Rapidrop products will void any warranty.
- Figure 104GG Grooved Gate Valve should be inspected and maintained during routine sprinkler system inspections by a competent person in accordance with national codes/requirements.
- Failure to follow these instructions could cause improper operation, resulting in personal injury and/or property damage.
- For further details and technical support please contact your Rapidrop sales representative.