

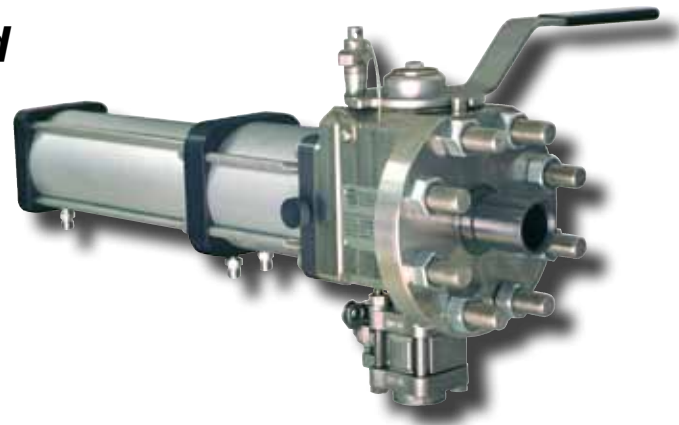

ISOLOK[®] SAL-DBB **Severe Duty Automatic Sampler**

U.S. Patent No. 7,481,124; 5,905,213; 6,164,145; 6,792,818 • Canadian Patent 2,418,263

**Double Block and Bleed
for Tough Applications**



ISOLOK[®] SAL-DBB SAMPLER

Features

- Totally encapsulated trunnion ball design
- Mounting via an integrated 300# ANSI Type flange
- Double block and bleed sampling valve for operator safety
- Simple single movement ¼ turn isolation valve
- Lightweight — weight of removed assembly is approximately 18 lb. (8 kg)
- Easy to maintain — plunger extends to provide access to wrench flats and seals
- Disassembly of cylinder assembly is not required to change plunger seals
- Patented "park position" feature

Options

- Optional "park position" cylinder allows sample plunger to dwell flush with nose end of sampler
- Port closures
- Several types of containers
- Sampler enclosures (with or without heater)
- Sample heating or refrigeration
- Optional materials of construction and seal choices

Description

The *ISOLOK[®] SAL-DBB* is the next generation of automatic sampler for harsh operating conditions, such as oil sand mining. Safety, reliability, convenience, and ease of service are all designed into this double block and bleed sampler.

Safety

The SAL-DBB offers the best operator protection on the market. The SAL-DBB can be fully isolated from the process prior to the removal of any bolts. To isolate, a single movement of a ¼ turn valve is all that is required. The sampler is designed with a large bleed port to alleviate plugging and for added operator protection.

Reliability and Convenience

The SAL-DBB features 300# ANSI Type design for high pressure requirements. A transitional sleeve is not needed, making mounting and aligning the sampler easier. Adapts to existing *ISOLOK[®] SAL* line adapters making it easy to install into existing sample points. Plunger life is increased due to short actuation length and dwell time.

Ease of Service and Maintenance

Less wear on seals means less maintenance. When maintenance is required, the removed assembly is lightweight and compact. No special tools are needed, and the sampler bolts are easily accessible for installation or removal. Plunger seal replacement can be done in the field without disassembling the entire sampler.

ISOLOK[®] samplers have a reputation for reliable service under tough job conditions. They can handle oil sand and other mining slurry sampling.

ISOLOK[®] SAL-DBB TECHNICAL DATA

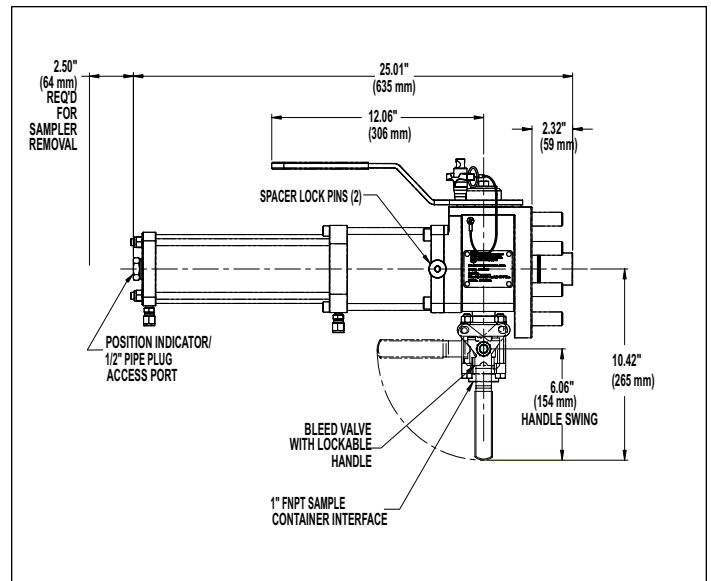
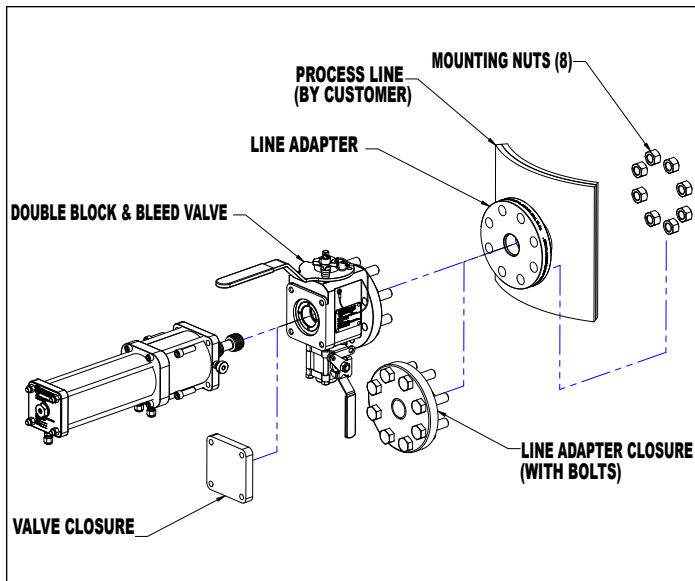

SPECIFICATIONS

Sample Volume per Cycle	8, 10 or 25 cc per cycle
Maximum Particle Size	9 mm (0.375")
Line Mounting Options	300# ANSI Type flange; line adapters designed and supplied by Sentry; line adapters available in stainless steel (hard facing available as option)
Wetted Materials of Construction	hardened steel, nickel tungsten carbide
Actuator and Static Seals	FKM, modified PTFE and filled PTFE
Plunger Seals	polyurethane or custom
Net weight, not including controller or accessories	Removable (cylinder) portion: approx. 18 lb. (8 kg) Valve: approx. 46 lb. (21 kg)
Canadian Registration Numbers (Alberta only)	Sampler: 0H10367.2 Line adapter: 0H08209.2 Adapter assembly for existing model SAL-B line adapters: 0H08210.2
CRN Pressure & Temperature Rating	1050 psig @ 100° F (72.4 bar @ 38° C) 720 psig @ 450° F (49.7 bar @ 232° C) Maximum

	Compressed Air Required		Maximum Operating Pressure (with corresponding air pressure)	
Minimum	60 psig	4.0 bar	300 psig (process) @ 60 psig (air)	20.7 bar (process) @ 4.0 bar (air)
Recommended	80 psig	5.5 bar	400 psig (process) @ 80 psig (air)	27.5 bar (process) @ 5.5 bar (air)
Maximum	100 psig	6.9 bar	500 psig (process) @ 100 psig (air)	34.4 bar (process) @ 6.9 bar (air)

WARNING

It is solely the responsibility of the end-user, through its own analysis and testing, to select products and materials suitable for their specific application requirements, ensure they are properly installed, safely applied, properly maintained, and limit their use to their intended purpose. Improper selection, installation, or use may result in personal injury or property damage.



SENTRY EQUIPMENT CORP

966 Blue Ribbon Circle North
Oconomowoc, WI 53066 USA
Tel: 262-567-7256 • Fax: 262-567-4523

E-mail:
sales@sentry-equip.com

Website:
www.sentry-equip.com

QUALITY MANAGEMENT SYSTEM
CERTIFIED BY DNV
ISO 9001:2008

For further information, contact:

Rometec srl

Via Alessandro Minuziano, 87 - 89
00128 - Roma
Tel 06-5061635 Fax 065061542
P.Iva 0412062100
www.rometec.it