

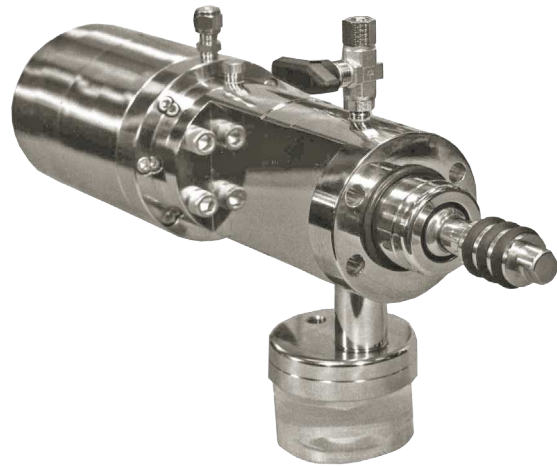

*The
Sampling
Connection*



ISOLOK[®] SERIES SAB SAMPLER

ISOLOK[®] SERIES SAB AUTOMATIC SAMPLER

Automatic Large Capacity Sampler for Liquids and Slurries

Features

- Two different models for sampling fixed volumes of 10 cc or 25 cc per sample cycle
- Can handle line pressures from vacuum up to 300 psi in most applications
- Rugged 316 stainless steel construction
- Batch or composite sampling
- Ideal for heavy or abrasive slurries

Options

- Port closures
- Line adapters
- Several types of containers
- Sampler enclosures (with or without heater)
- Sample heating or refrigeration
- Optional materials of construction and seal choices

Description

The ISOLOK[®] SAB provides accurate samples of liquids and slurries such as waste acid, resin bead slurry, bauxite mud and raw municipal sludge.

The ISOLOK[®] SAB operates when compressed air forces the plunger into the process line to capture a fixed volume of material. Compressed air then acts on the opposite side of the piston to retract the plunger to a position which allows the sample to drop into a container.

The operator is isolated from the process at all times by the sampler's seal design, and the sample captured in the container is "locked out" from external influences.

Metal parts are made of 316 stainless steel; other alloys are available. Process contact seals are filled-Teflon[®] for chemical applications or wear-resistant elastomers for abrasive slurries. Modular components allow selection of various bodies and plungers to meet the process application.

SAMPLING PROCESS

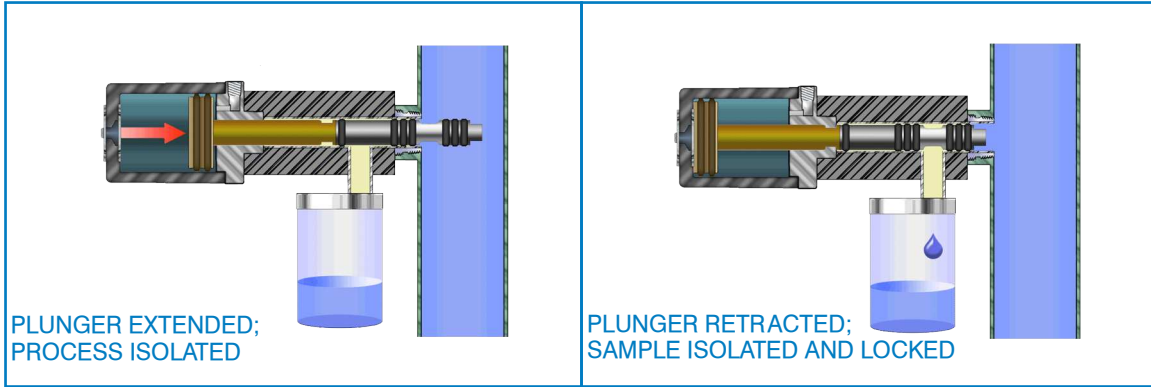

ISOLOK® SAB TECHNICAL DATA

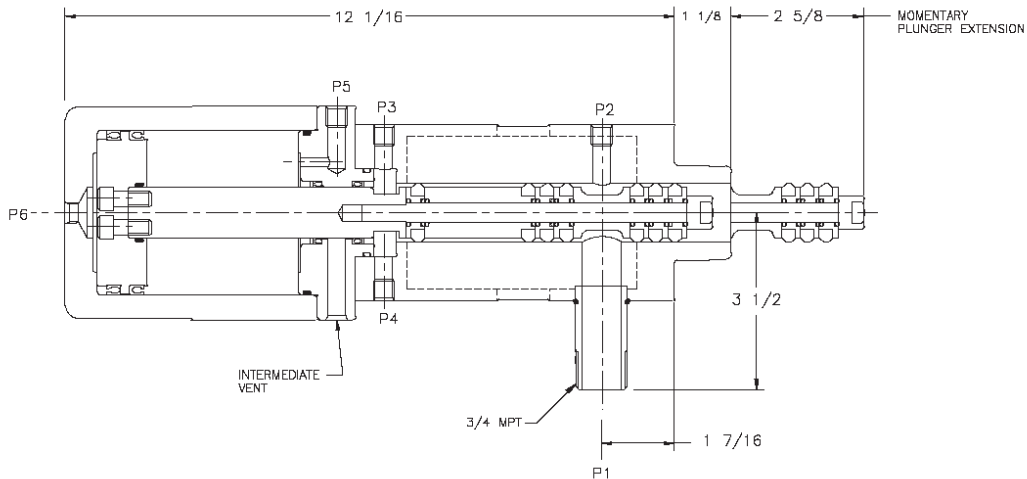

SPECIFICATIONS

Sample Volume per Cycle	Model SAB-25: 25 cc / 1.5 cu. in.; Model SAB-10: 10 cc / 0.6 cu. in.
Maximum Particle Size	9 mm / 0.375"
Basic Electrical Requirements (with Sentry controller)	115 VAC, single phase, 50/60 Hz
Line Mounting Options	MNPS thread, tri-clamp, instrument hub, ANSI flange
Compressed Air Requirements	60 psig minimum
Materials of Construction	316 stainless steel; other materials available
Plunger Seals	TFE, polyurethane, EPDM rubber, Kalrez® or custom
Net Weight, not including controller or accessories	28–32 lbs. / 12.7–14.5 kg

⚠ WARNING

It is solely the responsibility of the end-user, through its own analysis and testing, to select products and materials suitable for their specific application requirements, ensure they are properly installed, safely applied, properly maintained, and limit their use to their intended purpose. Improper selection, installation, or use may result in personal injury or property damage.



SENTRY EQUIPMENT CORP

PO Box 127
Oconomowoc, WI 53066 USA
Phone: 262-567-7256
Fax: 262-567-4523

E-mail:
sales@sentry-equip.com

Website:
www.sentry-equip.com

For further information, contact:

Rometec srl

Via Alessandro Minuziano, 87 - 89

00128 - Roma

Tel 06-5061635 Fax 065061542

P.Iva 0412062100

www.rometec.it

The Sampling Connection