



ISOLOK[®] SERIES MSC **Automatic Sampler**

***For Medium Viscosity
Sanitary Products***



ISOLOK[®] SERIES MSC SAMPLER

Features

- Samples medium viscosity materials and discharges them by gravity
- Collects a fixed sample volume of 14 cc per cycle
- Conformant to 3-A Sanitary Standards through third-party verification
- Ideal for liquids or slurries up to 1,000 centipoise

Options

- Port closures
- Line adapters
- Several types of containers
- Sampler enclosures (with or without heater)
- Sample heating or refrigeration
- Optional materials of construction and seal choices for non-3A applications.

Description

The *ISOLOK[®]* MSC series of samplers enable the collection of accurate samples of medium viscosity products such as cream or single-strength orange juice. The MSC delivers a fixed volume of sample with each cycle and includes direct mounting of wide-mouth labware plastic sample collection bottles (available in a variety of sizes). All metal parts are type 316 stainless steel with a polished finish. The sampler mounts onto the process line using a 2" Tri-Clamp ferrule mount held with a clamp and gasket. All product-contact seals are FDA-recognized elastomer compounds selected to meet application conditions.

Compressed air drives the sampler by forcing the plunger to reach into the process to capture a fixed volume of the material. Compressed air then acts on the opposite side of the piston to retract the plunger to a position which allows the sample to drop into a container. The operator is isolated from the process at all times by the sampler's seal design and the sample captured in the container is locked out from external influences.



SAMPLING PROCESS

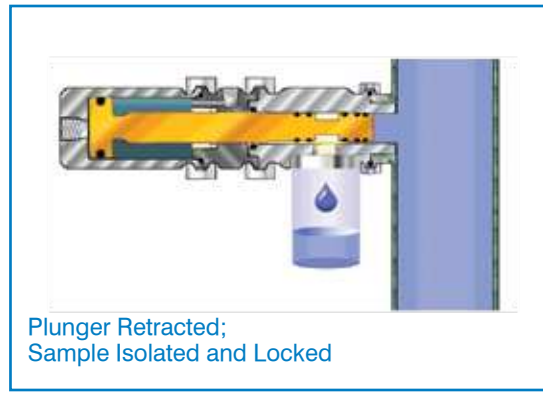
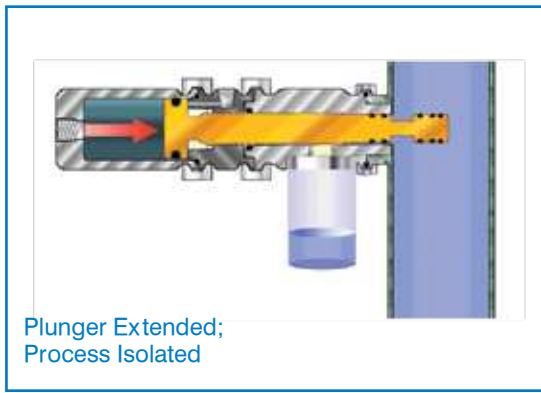

ISOLOK® MSC TECHNICAL DATA

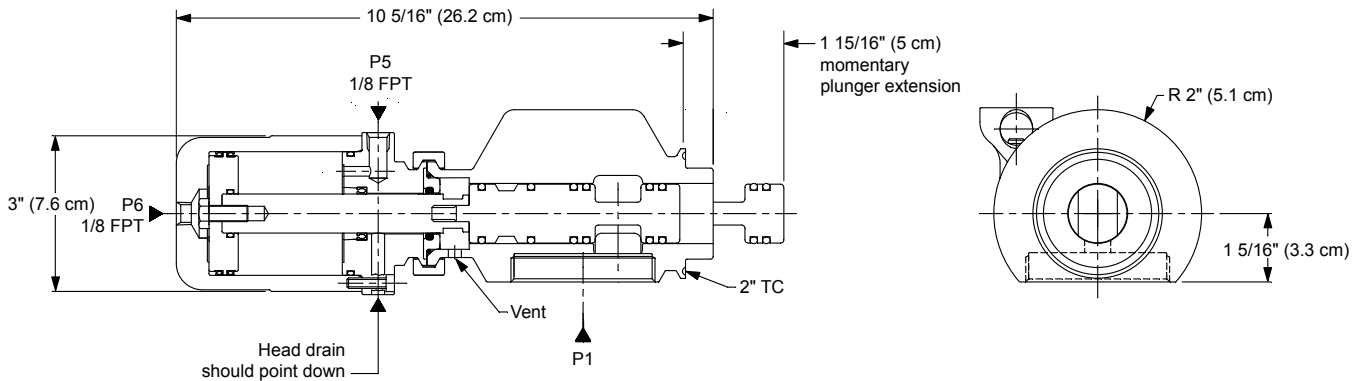

SPECIFICATIONS

Sample Volume per Cycle	max. 14 cc
Line Mounting Options	Tri-clamp or custom
Compressed Air Requirements	2 SCFM @ 90 psi (.05 m ³ /min @ 6.2 bar)
Materials of Construction	316 stainless steel
Actuator and Static Seals	TFE or custom
Plunger Seals	Buna-N or custom
Overall Dimensions, length x diameter	10.3" x 4" (26 cm x 10 cm)
Net weight, not including controller or accessories	16.6 lbs (7.5 kg)

WARNING

It is solely the responsibility of the end-user, through its own analysis and testing, to select products and materials suitable for their specific application requirements, ensure they are properly installed, safely applied, properly maintained, and limit their use to their intended purpose. Improper selection, installation, or use may result in personal injury or property damage.

CE European Authorized Rep:
OBELIS
Bd. General Wahis 53-1030
Brussels Belgium

Ex II 2GD TX



SENTRY EQUIPMENT CORP

966 Blue Ribbon Circle North
Oconomowoc, WI 53066 USA
Tel: 262-567-7256 • Fax: 262-567-4523

E-mail:
sales@sentry-equip.com

Website:
www.sentry-equip.com



For further information, contact:

Rometec srl

Via Alessandro Minuziano, 87 - 89
00128 - Roma
Tel 06-5061635 Fax 065061542
P.Iva 0412062100
www.rometec.it