

MODEL F195**DISPOSABLE IN-LINE FILTER**

Rometec srl - www.rometec.it - Rometec srl - www.rometec.it - Rometec srl - www.rometec.it

Flowmeter Accessories and Options

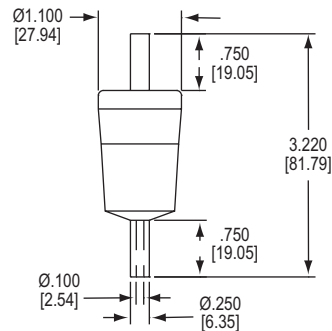

Remove 99.99% of unwanted particles from within your gas flow with the **Model F195 Disposable In-Line Filter**. Encapsulated microfiber filter elements are able to filter particles as small as 0.1 micron. Filters are completely disposable — simply remove the filter from your line and throw it away when it becomes dirty. The transparent nylon housing makes it simple to determine if the filter needs to be changed.

MODEL CHART

| Model | Description |
|-------|---------------------------|
| F195 | Disposable in-line filter |

LINE PRESSURE VS. FLOW

| Line Pressure (psig) | 1.5 | 10 | 20 | 30 | 40 | 60 | 80 | 100 | 125 |
|----------------------|-----|-----|-----|-----|-----|-----|-----|-----|-----|
| Gas Flow (scfm) | 0.6 | 0.9 | 1.3 | 1.6 | 2.0 | 2.7 | 3.5 | 4.2 | 5.7 |

SPECIFICATIONS

Filtration Efficiency: 99.99% (removal of 0.1 micron particles).

Housing Construction: Nylon.

Filter Tube Dimensions: 0.59 ID x 1.39 L.

Maximum Temperature: 230°F @ 0 psig (110°C @ 0 bar), 120°F @ 125 psig (49°C @ 9 bar).

Maximum Pressure: 125 psig (8.6 bar).

Maximum Differential Pressure: 60 psi (4 bar) (in-to-out flow direction), 20 psi (1.4 bar) (out-to-in flow direction).

Internal Volume: 11.5 cc (11.5 ml).

Connections: Barbed for 1/4" ID tubing.

Rometec srl - www.rometec.it - Rometec srl - www.rometec.it - Rometec srl - www.rometec.it