

Rometec s.r.l.

Via Alessandro Manzoni, 87 00128 Roma
Tel. 005001055 - Fax 005001342

Sito web: www.rometec.it - email: info@rometec.it

P. IVA 04120621000 - CCIAA RM 736916

Reg. Soc. Tribunale RM 9229/91 - Cap. soc. 46'482,00 €



Rometec srl - www.rometec.it - info@rometec.it - Rometec srl - www.rometec.it - info@rometec.it

ELECTRONIC FLOW SWITCHES

Features

- No Moving Parts
- Operates in Liquids, Gases and Slurries
- Can Detect Increase or Decrease of Flow
- 316L Stainless Steel Sensor
- Low Cost, Designed for Industrial OEM and End Users



Applications

- Low Flow Shut Down of Pumps
- Flow Indication/Verification
- Pump or Valve Seal Leakage
- Bearing Lubrication Flow Sensor
- HVAC Flow Monitor
- Safety Shower Flow Switch

FM Series

The FM series is designed to provide an extremely reliable flow switch at a very cost effective price. This series replaces the standard explosion proof enclosure utilized in our FX series with a general purpose enclosure.

The principle of operation measures a temperature differential between a heated and a reference temperature sensor (see figure 1). The differential varies as flow across the sensor changes. This allows the flow switch to detect the increase or decrease of flow of virtually all liquids, gases and slurries. Flow ranges are shown on the next page of this brochure in the set-point range chart. A conversion chart is also provided to covert volumetric flow to velocity.

The electronics feature a SPDT relay switch output with options for power input of 120 VAC, 12VDC, and 24 VDC or VAC. Calibration is easily performed by adjusting a potentiometer on the circuit board.

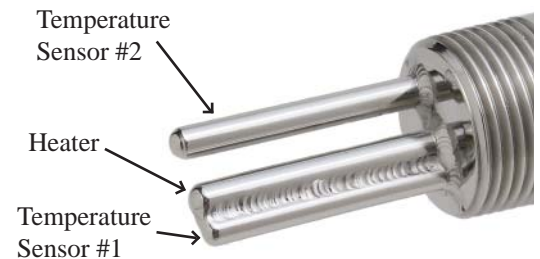

Temperature Differential = Temperature Sensor #1 Minus Temperature Sensor #2

Part Number/Order Entry Specification

FM -		Option																				
Process Connection	<table border="1"> <tr> <td>1/2" MNPT</td> <td>0</td> <td>5</td> <td>0</td> <td>0</td> </tr> <tr> <td>3/4" MNPT</td> <td>0</td> <td>7</td> <td>5</td> <td>0</td> </tr> <tr> <td>1" MNPT</td> <td>1</td> <td>0</td> <td>0</td> <td>0</td> </tr> </table>	1/2" MNPT	0	5	0	0	3/4" MNPT	0	7	5	0	1" MNPT	1	0	0	0	<table border="1"> <tr> <td>S</td> <td colspan="2">HIGH FLOW OPTION- CLEAN LIQUIDS/GASES, 1" MNPT ONLY</td> </tr> </table>			S	HIGH FLOW OPTION- CLEAN LIQUIDS/GASES, 1" MNPT ONLY	
1/2" MNPT	0	5	0	0																		
3/4" MNPT	0	7	5	0																		
1" MNPT	1	0	0	0																		
S	HIGH FLOW OPTION- CLEAN LIQUIDS/GASES, 1" MNPT ONLY																					
Power Input	<table border="1"> <tr> <td>12 VDC (+30%, -10%)</td> <td>B</td> </tr> <tr> <td>117 VAC (90-135 VAC)</td> <td>C</td> </tr> <tr> <td>24 VDC (+VAC (-10%)</td> <td>D</td> </tr> </table>	12 VDC (+30%, -10%)	B	117 VAC (90-135 VAC)	C	24 VDC (+VAC (-10%)	D	<table border="1"> <tr> <td>0</td> <td>1</td> <td>1.2" PROBE</td> </tr> <tr> <td>0</td> <td>2</td> <td>1.8" PROBE</td> </tr> <tr> <td></td> <td></td> <td>SPECIAL PROBE LENGTH, SPECIFY LENGTH IN INCHES</td> </tr> </table>			0	1	1.2" PROBE	0	2	1.8" PROBE			SPECIAL PROBE LENGTH, SPECIFY LENGTH IN INCHES			
12 VDC (+30%, -10%)	B																					
117 VAC (90-135 VAC)	C																					
24 VDC (+VAC (-10%)	D																					
0	1	1.2" PROBE																				
0	2	1.8" PROBE																				
		SPECIAL PROBE LENGTH, SPECIFY LENGTH IN INCHES																				

Rometec srl - www.rometec.it - info@rometec.it - Rometec srl - www.rometec.it - info@rometec.it

Optional Calibrator

Flow Switch Calibrator Model MC-5

- Displays mV output which is proportional to flow
- Induces signal to electronics for setting specified switch point
- Allows periodic switch point verification

This tool is not needed for a vast majority of users. It is useful when a user has large quantity of units and requires periodic verification of switch point calibrations.

This easy to use hand held, self powered instrument can be used in conjunction with all single or dual switch point circuit boards. By simply plugging this instrument into the circuit board, the user can interrogate all functions of the flow switch.



Flow Switch Applications

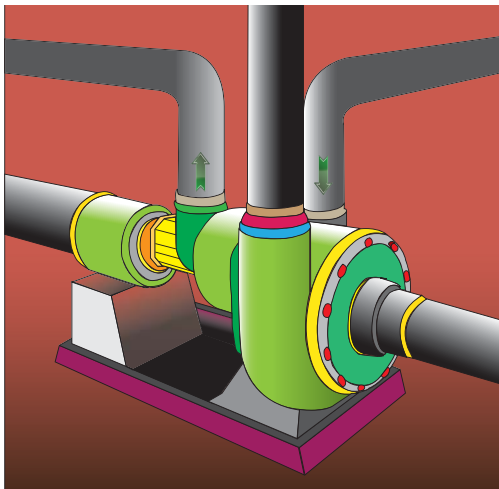

- Pump Protection: Automatic shut down on low or no flow
- Bearing Lubrication: Detects loss of lubricant flow
- Seal Leakage: Verifies positive seal flow or detects excessive leakage indicating maintenance requirement
- Chemical Feed and Metering Pumps: Indicates low or no flow of chemical additives to process
- Safety Shower/Eye Wash Station: Automatic annunciation of potential danger to plant personnel
- Analyzer/ Gas Chromatographs: Confirms continuous sample flow to instruments
- Control Rooms: Verifies flow when fans, pumps or valves are energized

- Purge Air: Detects loss of flow for process or plant safety
- Spray Nozzles: Detects nozzle blockage in coating applications
- Relief Valve/Rupture Disks: Alarms on flow or leakage of safety relief valves or rupture disks
- Chiller Lines: Automatic shut down of chillers on low or no flow
- Heater Burnout Prevention: Heater shutdown on loss of flow to prevent overheating of elements
- Tank Car Loading: Senses dry line or phase change from liquid to nitrogen gas flow
- Drain Line Sensor: Capable of detecting flow in partially filled lines
- Agitation Monitor: Positive indication of agitation in tanks

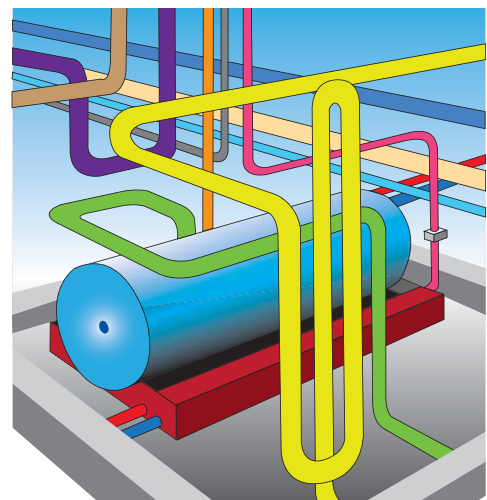

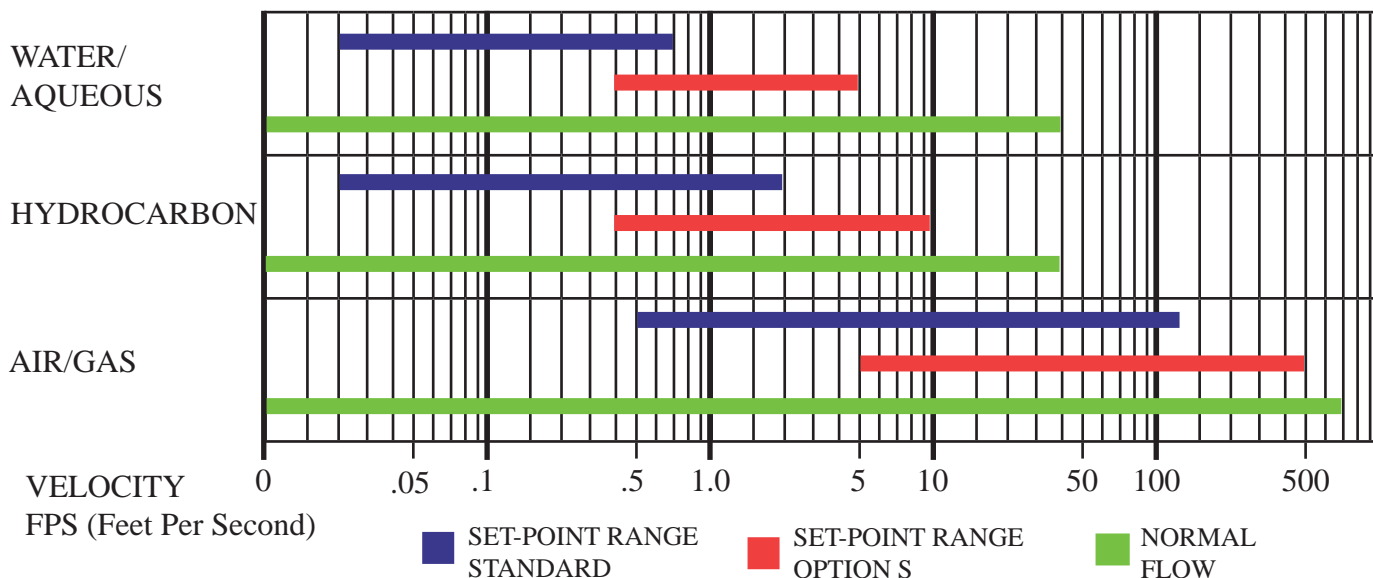

Conversion Table

Volumetric (GPM or CFM) to Velocity (Feet per Second - FPS)

Line Size	1/8"	1/4"	3/8"	1/2"	3/4"	1"	1.25"	1.5"	2"	2.5"	3"	3.5"	4"	5"	6"
Liquid Multiplier	5.65	3.08	1.68	1.06	.602	.371	.215	.158	.096	.067	.0434	.0325	.0252	.0160	.0111
Air Multiplier	42.19	23.06	12.57	7.91	4.50	2.78	1.61	1.18	.716	.502	.325	.243	.188	.120	.083

Line Size	8"	10"	12"	14"	16"	18"	20"	24"
Liquid Multiplier	.0064	.00407	.00287	.00237	.00182	.00143	.00115	.000798
Air Multiplier	.0480	.0304	.0209	.0177	.0136	.0107	.00863	.00597

Examples:

- 1) 100 CFM in 3" Line = $100 \times .325 = 32.5$ FPS
- 2) 10 GPM in 3" Line = $10 \times .0434 = .434$ FPS

Specifications

Sensor Head

Material of Construction: 316L Stainless Steel Standard

Operating Temperature: -50 to +250F (-46 to +121C)

Operating Pressure: Vacuum to 4000 PSIG (275 Bar)

Response Time: From 3 Seconds

Repeatability $\pm 0.5\%$ of Range at Constant Conditions

Process Connection: 3/4" MNPT, 1" MNPT, Option 1/2" MNPT

Probe Length: 1.8", 1.2" Option Customer Specified

Electronics

Housing: Powder Coated General Purpose

Temperature: -50 to +150F (-46 to +65C)

Power Input: 90-135 VAC, 50/60 Hz, 4 Watts
Option 12 VDC, 24 VDC/VAC

Relay Output: SPDT 2 Amps Resistive

Electrical Connection: 1" FNPT

Shipping Weight: 4 lbs



Rometec srl

Via A. Minuziano 89, 0128, Roma

Tel: 06 5061635

INFO@ROMETEC.IT

WWW.ROMETEC.IT

Manufacturer of Industrial Instrumentation

ELECTRONIC FLOW SWITCHES

Features

- No Moving Parts
- Operates in Liquids, Gases and Slurries
- Can Detect Increase or Decrease of Flow
- 316L Stainless Steel Sensor
- Lowest Cost, Designed for Industrial OEM and End Users



FD Series

Applications

- Low Flow Shut Down of Pumps
- Flow Indication/Verification
- Pump or Valve Seal Leakage
- Bearing Lubrication Flow Sensor
- HVAC Flow Monitor
- Safety Shower Flow Switch

The FD series is designed to provide an extremely reliable flow switch at a very cost effective price. This series replaces the standard explosion proof enclosure utilized in our FX series with a NEMA 4X enclosure.

The principle of operation measures a temperature differential between a heated and a reference temperature sensor (see figure 1). The differential varies as flow across the sensor changes. This allows the flow switch to detect the increase or decrease of flow in virtually all liquids, gases and slurries. Flow ranges are shown on the next page of this brochure in the set-point range chart. A conversion chart is also provided to convert volumetric flow to velocity.

The electronics feature a SPDT relay switch output with power input of 24 VDC. Calibration is easily performed by adjusting a potentiometer on the circuit board.

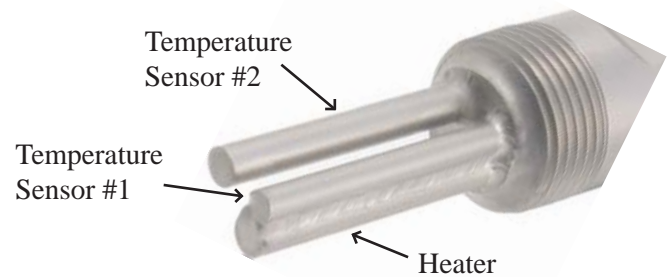

Temperature Differential = Temperature Sensor #1 Minus Temperature Sensor #2

Figure 1

Part Number/Order Entry Specification

	F	D	-	0	7	5	0	D	-			Probe Length
Process Connection	3/4" MNPT			0	7	5	0			0	1	1.2" PROBE
										0	2	1.8" PROBE
Power Input	24 VDC (±5%)							D				SPECIAL PROBE LENGTH, SPECIFY LENGTH IN INCHES

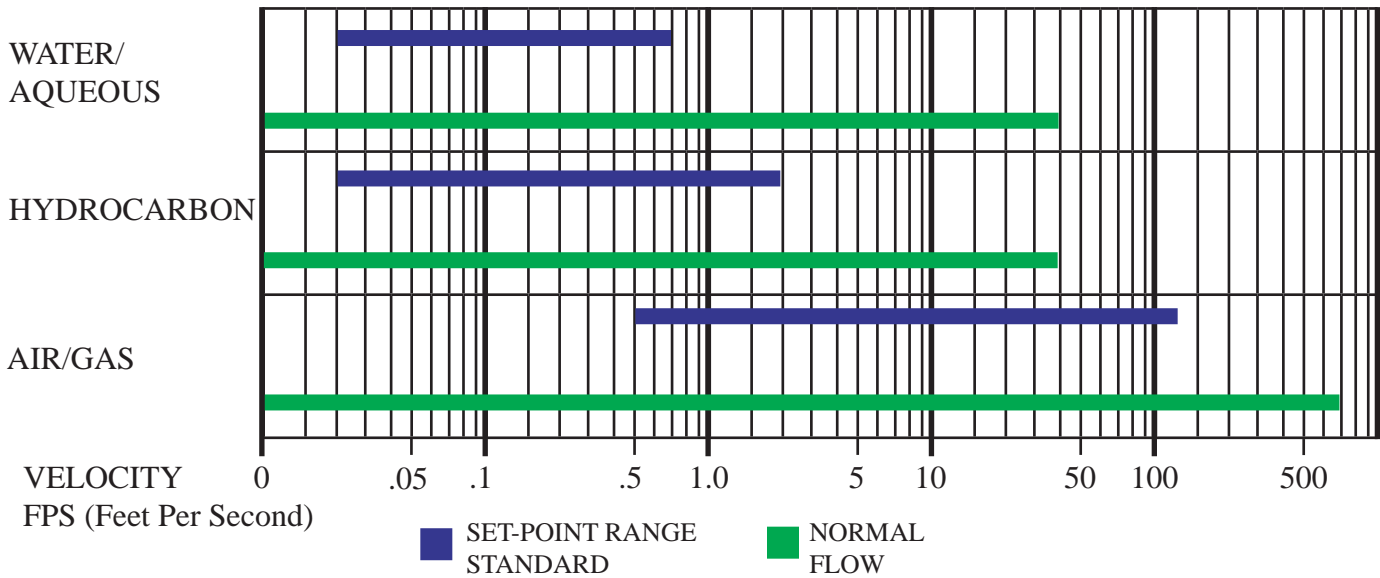

Conversion Table

Volumetric (GPM or CFM) to Velocity (Feet per Second - FPS)

Line Size	1/8"	1/4"	3/8"	1/2"	3/4"	1"	1.25"	1.5"	2"	2.5"	3"	3.5"	4"	5"	6"
Liquid Multiplier	5.65	3.08	1.68	1.06	.602	.371	.215	.158	.096	.067	.0434	.0325	.0252	.0160	.0111
Air Multiplier	42.19	23.06	12.57	7.91	4.50	2.78	1.61	1.18	.716	.502	.325	.243	.188	.120	.083

Line Size	8"	10"	12"	14"	16"	18"	20"	24"
Liquid Multiplier	.0064	.00407	.00287	.00237	.00182	.00143	.00115	.000798
Air Multiplier	.0480	.0304	.0209	.0177	.0136	.0107	.00863	.00597

Examples:
 1) 100 CFM in 3" Line = 100 x .325 = 32.5 FPS
 2) 10 GPM in 3" Line = 10 x .0434 = .434 FPS

Specifications

Sensor Head

Material of Construction: 316L Stainless Steel Standard

Operating Temperature: -50 to +250F (-46 to +121C)

Operating Pressure: Vacuum to 4000 PSIG (275 Bar)

Response Time: From 3 Seconds

Repeatability: ± 0.5% of Range at Constant Conditions

Process Connection: 3/4" MNPT

Probe Length: 1.8", 1.2" Option Customer Specified

Electronics

Housing: Powder Coated NEMA 4X

Temperature: -50 to +150F (-46 to +65C)

Power Input: 24 VDC ± 5%

Relay Output: SPDT 2 Amps Resistive at 24 VDC or 0.5 Amps at 120 VAC

Electrical Connection: 3/4" FNPT

Shipping Weight: 2 lbs