

## PIV300FJ Non Rising Stem Resilient Wedge Gate Valve

UL Listed / FM Approved  
Flange x Mechanical Joint

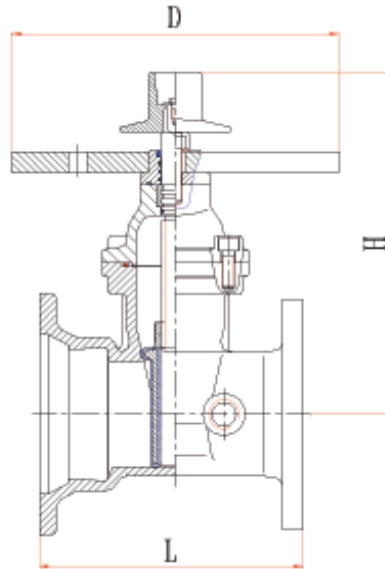

### Valve Standard

Comply with AWWA C515

### Pressure & Rating

Working Pressure: 20.7 Bar  
Temperature: -10 °C to 120 °C

**Flange Ends:** EN1092-2 PN10 / PN16, ANSI B16.1 Class 125 etc. (Please specify on order).

**Mechanical-Joint Dimension:** Comply to ANSI / AWWA C153 / A21.53.

**Fusion Bonded Epoxy Coated Interior and Exterior**

### Dimensions

Size	100 mm	150 mm	200 mm	250 mm	300 mm
L	241.5	279.5	305.0	352.5	367.0
H	305.0	417.0	525.0	621.0	711.0
D	305.0	305.0	305.0	305.0	305.0

### Material Specifications

Item	Material	ASTM Spec
NPT Plug	Brass	B16, C36000
Post Plate	Ductile Iron	A536 65-45-12
Wrench Nut	Ductile Iron	A536 65-45-12
Gland	Ductile Iron	A536 65-45-12
Thrust Collar	Bronze	ASTM B62
Bonnet	Ductile Iron	A536 65-45-12
Gasket	EPDM	Commercial
Stem	Stainless Steel	AISI 420
Disc Nut	Bronze	ASTM B62
Wedge Disc	Ductile Iron with EPDM Coated	
Body	Ductile Iron	A536 65-45-12