



ALVT

Vortex Flowmeter

ALVT Series

GENERAL

Vortex flow sensing technology relies on measuring the number of vortex pulses generated by a bluff body immersed in the flow stream. A piezo-electric sensor mounted outside of the fluid flow serves as a transducer to convert the vortex pulses into electrical pulses which are then counted and converted into useful engineering units by the microprocessor in the meter's display module. By utilizing a design that is free of moving parts and having a transducer that is isolated from the process fluid, the vortex meter offers a number of advantages including low pressure drop, long service life, good particle tolerance, and compatibility with a wide array of fluids. Vortex technology is one of the few flow measurement techniques that is capable of measuring liquids, compressed gases, and steam.

SMC's ALVT Series meters are available for line sizes ranging from ½" through 20" and are offered with in-line flanged or wafer style mounting as well as insertion-type with an optional hot-tap ball valve. The ALVT may be calibrated for liquid, gas, or steam service and is available with integrated temperature and pressure measurement for performing compensated mass-flow calculations.



FEATURES

- Suitable for a wide variety of applications with steam, gas, and liquid medias
- No moving parts, high reliability and durability
- Piezo-electric sensor isolated from the process fluid
- Error messages displayed for or erratic flows and flows outside of calibrated ranges
- Field calibration possible with integral or remote electronics and keypad
- True 2-wire 4-20 mA interface
- Wide measuring range, turn-down ratio of 10:1
- Insertion meters can be installed vertically, horizontally or in angled pipelines
- Available with an integrated mass flow vortex
- ALVTIS (insertion) can be hot-tapped with ball valve and retractable assembly



SPECIFICATION

- Process Connections: wafer(standard), Flanged; Insertion;
- Process temperature : 23~482 °F (-5~+250 °C) (with LCD display)
- Operating pressure : 232 psi (1.6MPa) std; up to 928 (6.4 Mpa) optional
- Velocity Range : Depends on fluid, pressure and temperature
- Liquids : 0.6~6 m/s
- Gas & Steam : 7~45 m/s
- Accuracy : 1.0% for liquid, 1.5% for gas and steam
- Repeatability : 0.33% for liquid, 0.5% for gas
- Turn down ratio : 10:1 (liquids)
- Material : SS #304
- Signal output : Pulse output, 2-wire 4~20mA_{DC}, RS485, Hart, Modbus
- RAM Back-up : Lithium Battery, 3.6V_{DC}
- Housing protection : IP65; IP67
- Ex Exid II B T4; Exib II C T 4
- Cable: 30' (10 m) included for remote version
- weight (approximate) : Wafer: 22~29 lbs (10~13kg) to 12" (DN300)
Flange: Contact factory for flange weight.
Insertion: 12 lbs (5.5kg) to 20" (*DN500)
- Signal Interface : RS485, HART
- Display units : m³/h, kg/hr
- Keypad : Rate, Total
- Power supply : 110/220 V_{AC} or isolated 14~36 V_{DC}
- NIST traceable : Liquids and gasses only
- Data storage : EPROM storage up to 5 years
- Data logger : Reading, sampling Times 0.5 S

ALVT

Dimensions in mm

Flange

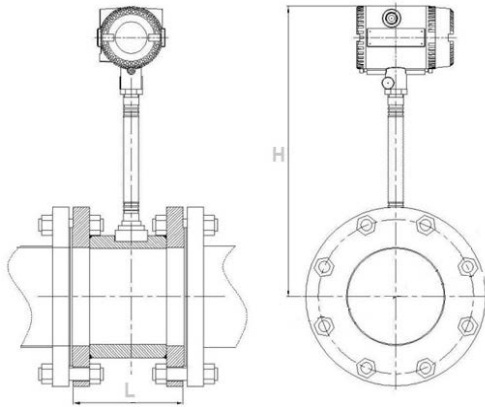

DN	L ± 3		H ± 3		Weight (kg)	
	class	class	class	class	class	class
	150#	300#	150#	300#	150#	300#
25	180	180	390	390	4.68	5.68
32	180	180	390	390	5.42	6.82
40	180	180	400	400	5.97	8.36
50	180	200	400	400	7.58	8.84
65	200	200	400	410	10.4	11.96
80	200	200	415	435	12.39	15.75
100	220	220	430	457.5	17.24	23.89
125	220	220	430	481.5	19.29	30.63
150	220	220	505	522	24.82	39.91
200	220	220	550	579.5	35.73	58.79
250	250	250	590	632	51.93	85.16
300	300	300	630	694.5	76.1	122.4

Wafer

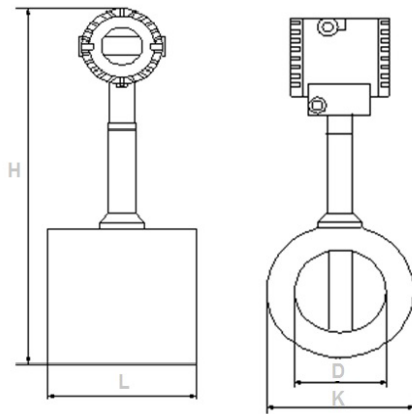

DN	L ± 3	D ± 3	K ± 3	H ± 3	Weight
15	65	75	130	331	4.01kg
20				328.5	3.90kg
25				326	3.76kg
32	70	80	145	332.8	4.11kg
40				337.8	4.35kg
50	75	94	160	348	4.77kg
65		105	180	361	5.09kg
80	84	120	192	376	6.19kg
100	90	140	230	397	7.61kg
125	100	165	242	423	9.89kg
150	120	190	280	448	13.44kg
200	150	240	335	501	21.89kg
250	160	290	405	549	30.51kg
300	170	340	460	599	40.85kg

Insertion

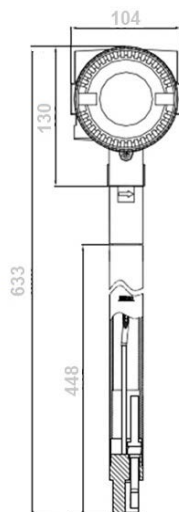

DN	L ± 3	H ± 3	Weight
80-500	104	633	5.5 kg

Mass flow of saturated steam (kg/hr)

Pressure	0.3 Mpa		0.4 Mpa		0.6 Mpa		0.7 Mpa		0.8 Mpa		1 Mpa		1.2 Mpa		1.5 Mpa	
Temp	133.5 °C		143.6 °C		158.9 °C		165 °C		170.7 °C		179.9 deg C		188 °C		198.4 °C	
Density	1.615 Kg/m ³		2.163 Kg/m ³		3.17 Kg/m ³		3.667 Kg/m ³		4.162 Kg/m ³		5.147 Kg/m ³		6.127 Kg/m ³		7.602 Kg/m ³	
DN15	11	63	12	73	14	88	15	85	16	101	18	112	19	123	23	136
DN20	13	102	15	116	18	141	19	151	20	161	22	179	24	196	27	218
DN25	17	133	19	153	23	185	25	199	27	212	30	236	32	257	36	287
DN32	30	236	34	271	41	328	44	352	47	375	52	417	57	455	63	507
DN40	34	340	39	390	47	470	51	510	54	540	60	600	66	660	73	730
DN50	63	630	73	730	88	880	95	950	101	1,010	112	1,120	122	1,220	136	1,360
DN65	106	1,060	121	1,210	146	1,460	158	1,580	168	1,680	187	1,870	204	2,040	227	2,270
DN80	148	1,480	170	1,700	205	2,050	221	2,210	235	2,350	262	2,620	285	2,850	318	3,180
DN100	222	2,220	242	2,420	293	2,930	315	3,150	336	3,360	374	3,740	408	4,080	454	4,540
DN125	318	3,180	363	3,630	440	4,400	473	4,730	504	5,040	561	5,610	612	6,120	681	6,810
DN150	423	4,230	484	4,840	586	5,860	631	6,310	672	6,720	747	7,470	815	8,150	908	9,080
DN200	847	8,470	969	96,900	1,173	11,730	1,262	12,620	1,344	13,440	1,495	14,950	1,631	16,310	1,815	18,150
DN250	1,270	12,700	1,453	14,530	1,769	17,690	1,892	18,920	2,016	20,160	2,242	22,420	2,446	24,460	2,725	27,250
DN300	2,116	2,160	2,422	24,220	2,932	29,320	3,154	31,540	3,360	33,600	3,737	37,370	4,077	40,770	4,541	45,410

Note: Pressures shown in table are gauge pressure

Mass flow of superheated steam (kg/hr)

ID (mm)	min flow	max flow
15	8.24 $\sqrt{\rho}$	49.5 $\sqrt{\rho}$
20	9.88 $\sqrt{\rho}$	79 $\sqrt{\rho}$
25	13.12 $\sqrt{\rho}$	104 $\sqrt{\rho}$
32	23 $\sqrt{\rho}$	184 $\sqrt{\rho}$
40	26.65 $\sqrt{\rho}$	265 $\sqrt{\rho}$
50	49.41 $\sqrt{\rho}$	494 $\sqrt{\rho}$
65	82.35 $\sqrt{\rho}$	585 $\sqrt{\rho}$
80	115.3 $\sqrt{\rho}$	823 $\sqrt{\rho}$
100	164.7 $\sqrt{\rho}$	1,153 $\sqrt{\rho}$
125	247.1 $\sqrt{\rho}$	1,647 $\sqrt{\rho}$
150	329.4 $\sqrt{\rho}$	2,471 $\sqrt{\rho}$
200	658.8 $\sqrt{\rho}$	3,294 $\sqrt{\rho}$
250	988.2 $\sqrt{\rho}$	6,588 $\sqrt{\rho}$
300	1,647 $\sqrt{\rho}$	9,882 $\sqrt{\rho}$

Note:

ρ ----density of the superheated steam under operating conditions (Kg/m³)

Volumetric flow of gas (N m³/hr)

ID (mm)	Flow range	Frequency- Hz
15	5-30	460-3700
20	6-50	220-3400
25	8-60	180-2700
32	14-100	130-1400
40	18-180	90-1550
50	30-300	80-1280
65	50-500	60-900
80	70-700	40-700
100	100-1000	30-570
125	150-1500	23-490
150	200-2000	18-360
200	400-4000	13-325
250	600-6000	11-220
300	1000-10000	9-210

Note: Standard conditions 20 °C, 0.1MPa

(absolute pressure), or under atmosphere at 20 °C

Volumetric flow of liquid (m³/hr)

ID (mm)	Flow range	Frequency- Hz
15	1.5-6	90-900
20	1.2-8	40-600
25	2-16	35-400
32	2.2-20	20-250
40	2.5-25	10-240
50	3.5-35	8-190
65	6-60	7-150
80	13-130	6-110
100	2-200	5-90
125	30-300	4.5-76
150	50-500	3.8-60
200	100-1000	3.2-48
250	150-1500	2.5-37.5
300	200-2000	2.2-30.6

**** Please contact your local Smartmeasurement™ application engineer**

You also need to provide the following information:

Type of Fluid (liquid/gas or steam)	Please provide the name of your fluid, including operating density and viscosity
Full Scale Flow	Maximum and minimum flow rates, units must be Kg/hr., Lb./hr., LPM or GPM
Line Size	Please specify your pipe size as well connection type (flange, threaded)
Process Pressure and Temperature	We will calibrate your meter as close to your operating conditions as possible
Type of Electronics	Please indicate if you want integral or remote electronics
Power Requirements	Please specify your power requirements such as 24 V _{DC} or 115 V _{AC} or 230 V _{AC}

➤ Model Selection Guide

ALVT meters													
Example:ALVT-2-3-40-D-1-2-0-N-1-NNN													
ALVT-	**	**	_**	**	_**	**	**	_**	**	**	**	**	Description
Flanged	1											Style	
Wafer	2												
Insertion- fixed	3												
Insertion- with ball valve	4												
Liquid	2											Fluid	
Gas	3												
Steam	4												
Inline type ½" – 12" (DN15–DN300)	**											Line Size	
Integral with digital display - standard	D											Display	
Remote with 5m cable	R												
13.5–45 V _{DC} - Standard	1											Power Supply	
3.6V lithium battery -no output	2												
No output	0											Signal Output	
Pulse output	1												
Two wire 4-20mA DC output	2												
No communication	0											Communication	
RS-485 Communication without 4-20mA	3												
Hart Communication @ 4-20mA	5												
Standard -40~482 °F (-40 ~ 250 °C)	N											Temperature	
High Temp 382~660 °F (250 ~350 °C)	H												
232 psi (1.6MPa)	1											Pressure	
363 psi (2.5MPa)	2												
580 psi (4.0MPa)	3												
928 (6.4MPa)	4												
None	N											Explosion Proof	
Explosive Isolated	G												
Intrinsically safe	B												
Standard material - SS #304	NN											Options	
Special material - SS #316	316												
Mass flow without PT100 RTD and pressure transmitter	MS												
Mass flow with PT100 RTD and pressure transmitter	MT												
Flow computer - 24 V _{DC} power, 4-20mA output, LED display	FC												